

# **E.S.V. Fuzz Kit Instructions**

<b>Parts Checklist.....</b>	<b>page 2</b>
<b>Populating the Circuit Board.....</b>	<b>page 3 - 7</b>
<b>Assembly.....</b>	<b>page 8</b>
<b>Mounting the Circuit Board.....</b>	<b>page 9 - 12</b>
<b>Wiring.....</b>	<b>page 13</b>
<b>Orienting the Transistors/Finish up.....</b>	<b>page 14 - 15</b>
<b>Schematic.....</b>	<b>page 16</b>
<b>Troubleshooting.....</b>	<b>page 17 - 24</b>

## Parts Checklist for Ultimate Fuzz Kit

### Resistors:

- 1 - 470ohm (yellow/purple/brown/gold)
- 1 - 4.7k (yellow/purple/red/gold)
- 1 - 33k (orange/orange/orange/gold)
- 1 - 100k (brown/black/yellow/gold)
- 1 - 1M (brown/black/green/gold)

### Trimpot:

- 1 - 25k trimmer

### Capacitors:

- 1 - 0.1uf film (flat yellow)
- 1 - 2.2uf aluminum electrolytic
- 1 - 22uf aluminum electrolytic

### Transistors:

- 2 - AC127/01 NPN germanium transistors
- 2 - SS-9013 NPN silicon transistors (these are for test purposes)
- 2 - Transistor sockets

**Potentiometers: SNAP THE SMALL TABS ON THE TOPS OF THE POTS OFF WITH A PAIR OF NEEDLE NOSE PLIERS**

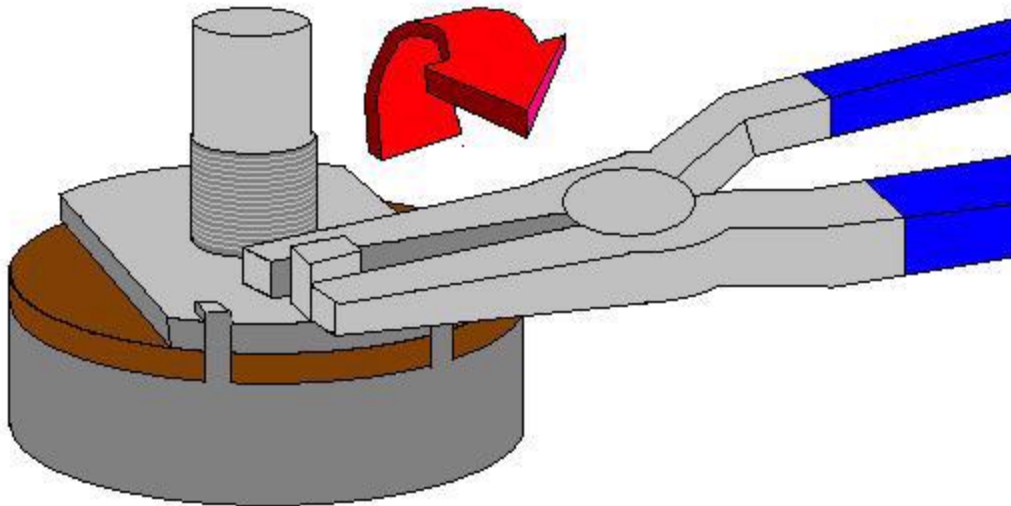

- 1 - A500K Audio Volume pot

- 1 - B1K Linear Fuzz pot

### Hardware:

- 1 - predrilled enclosure w/ 4 screws
- 1 - vintage fuzz kit circuit board
- 1 - 3pdt footswitch
- 2 - knobs
- 1 - AC adaptor jack
- 1 - 1/4" stereo jack
- 1 - 1/4" mono jack
- 1 - battery snap
- 1 - red LED
- hook-up wire

# Populating the Circuit Board

Step 1: Add all the resistors. Resistors are not polarized and can be inserted in either direction.

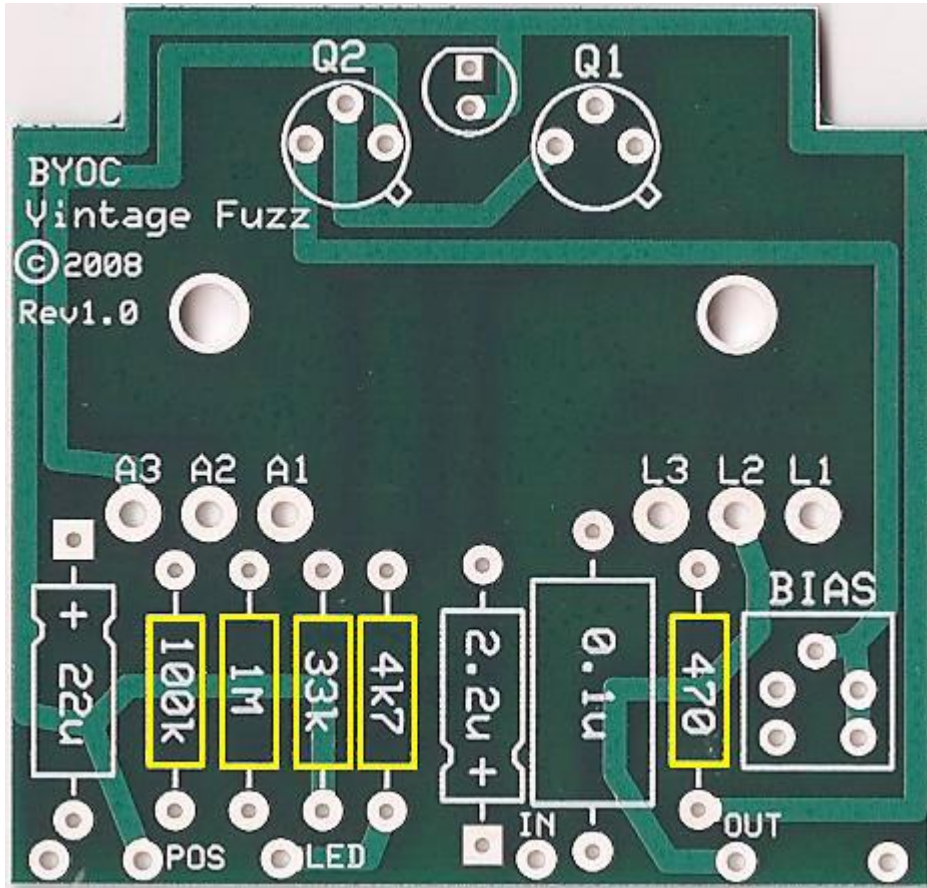

Step 2: Add the transistor sockets. Make sure that the tab on the socket matches up with the tab on the circuit board. Do not add the transistors yet. Do not solder the transistors to anything. Only solder the sockets.

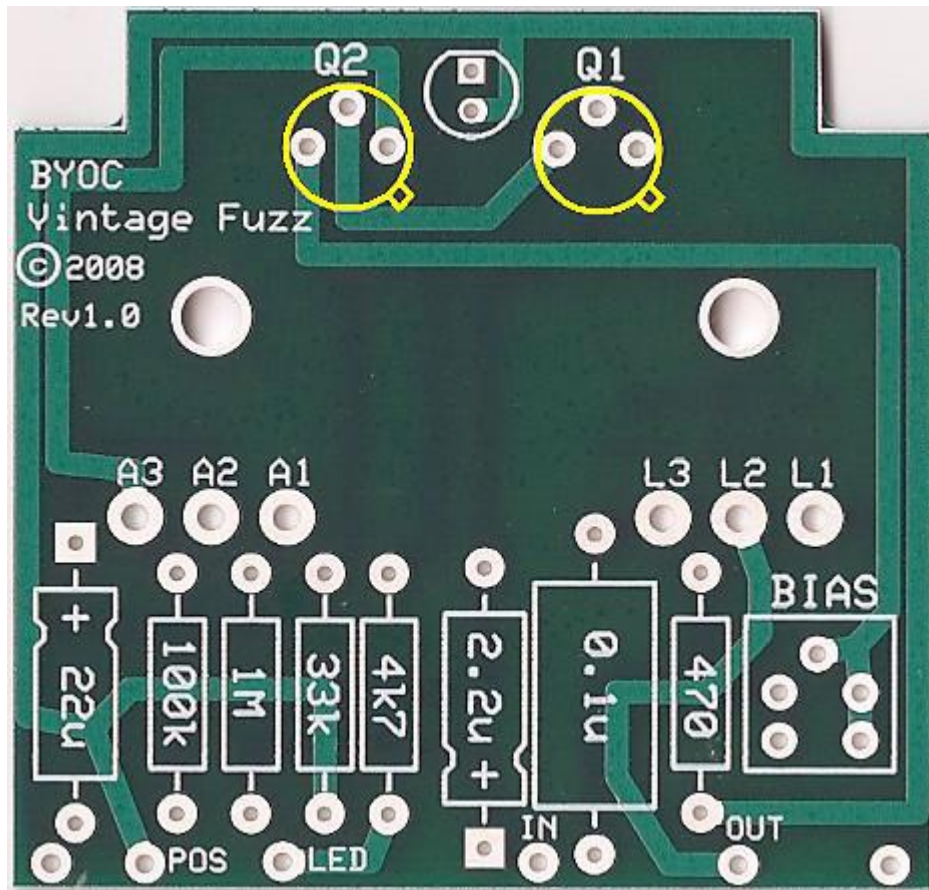

Step 3: Add the bias trimpot. The board is designed to accept several brands of trimmers, but there is only one way to insert the trimpot that comes with the kit. Directions for setting the trimpot are in the “finishing touches” portion of the directions.

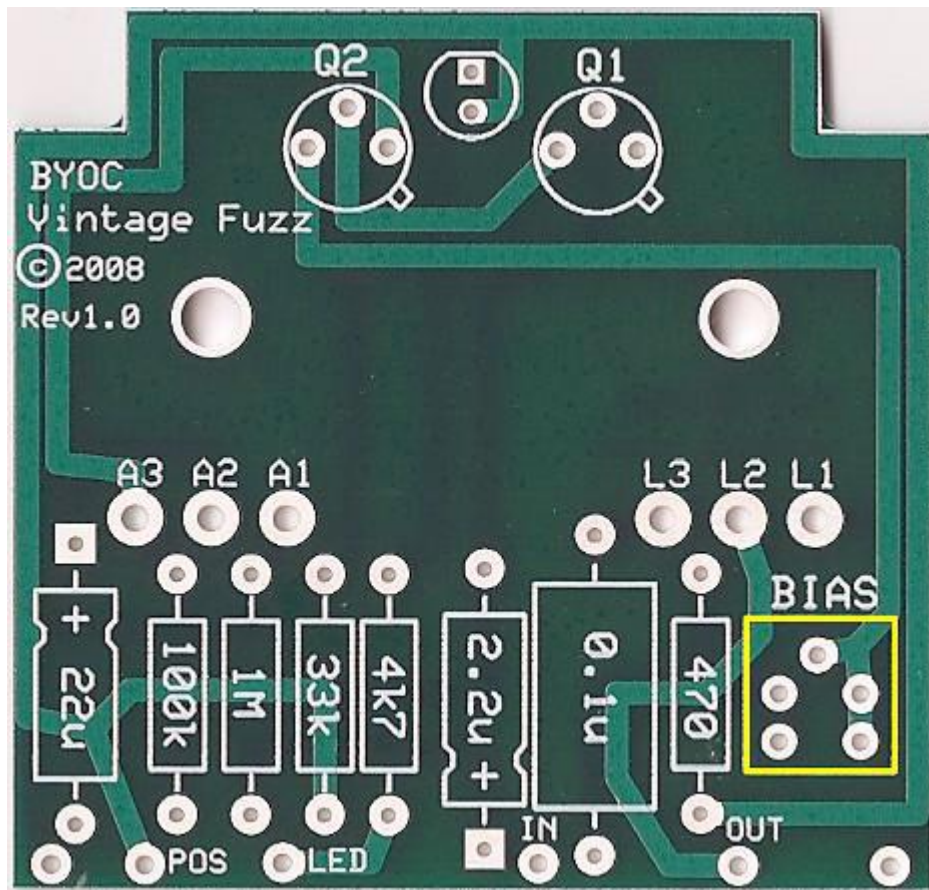

Step 4: Add the .1uf film capacitor. This is non-polarized so it can go in either direction.

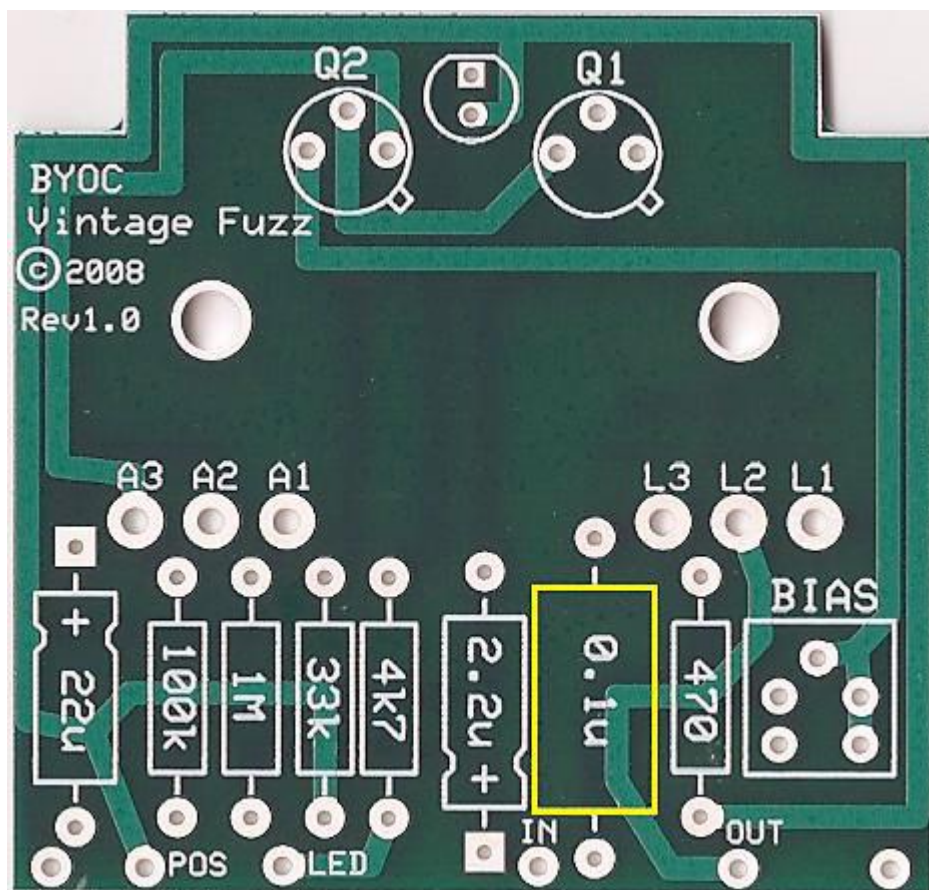

Step 5: Add the aluminum electrolytic capacitors. These are polarized, meaning there is a positive and negative end. The positive end will go into the square solder pad. The positive end of the capacitor will have an indented collar around it.

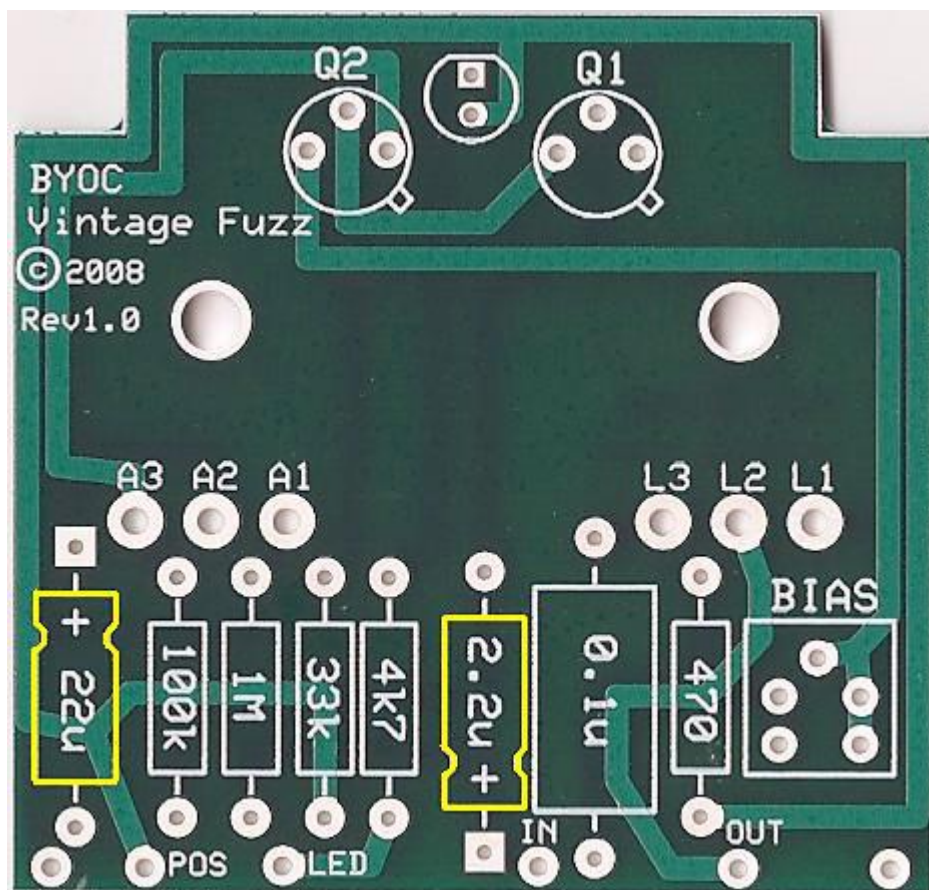

# Assembly

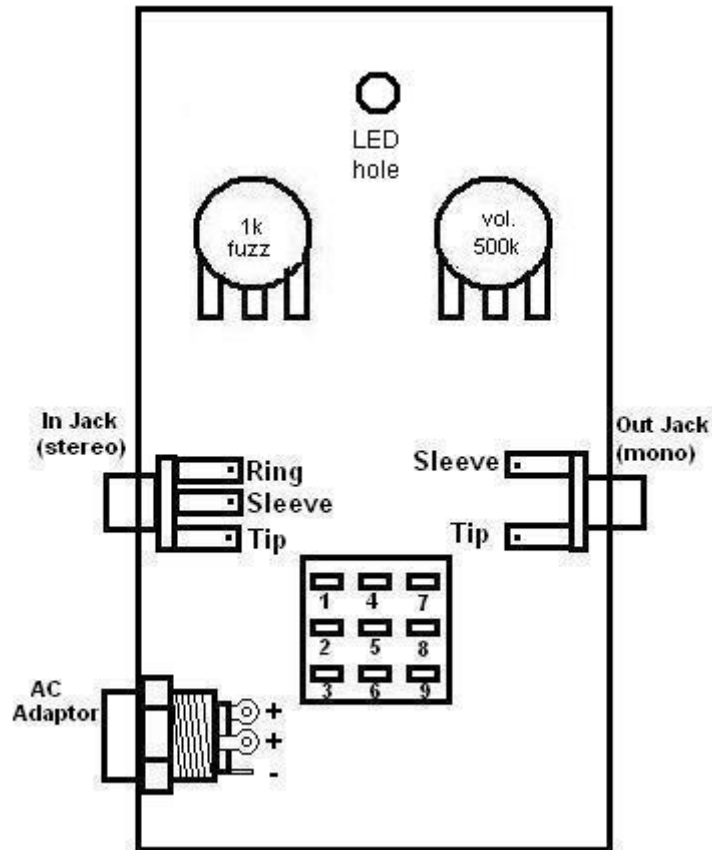

1. Install the jacks first. If you are looking down inside the enclosure, the mono jack goes on the right side and the stereo jack goes on the left. Place the washer on the outside of the enclosure. Use a 1/2" wrench to tighten.
2. Install the AC adaptor jack. The bolt goes on the inside. Use a 3/4" or 14mm wrench to tighten.
3. Install the potentiometers so that the solder lugs are pointing down. The 1k (fuzz/attack) pot goes on the left side and the 500k (volume) pot goes on the right. The washers go on the outside. Use a 10mm wrench to tighten but only snug. Do not over tighten the pots.
4. Install the footswitch. The first bolt and metal washer go inside. The plastic washer and second bolt go on the outside. It does not matter which side you designate as the "leading edge" of the footswitch as long as you orientate it so that the flat sides of the solder lugs are aligned in horizontal rows, not vertical columns.



# Mounting the Circuit Board

**PC Mounted Potentiometers:** Some kits will come with PC mounted pots depending upon availability. If your kit has PC mounted pots follow these steps for mounting the circuit board.

**Step1:** Understand that the LED, and both potentiometers will be mounted directly to the underside of the PCB. You should do the actual soldering on the topsid of the PCB. Read through all the steps in this portion before doing anything so that you can get the “big picture”.

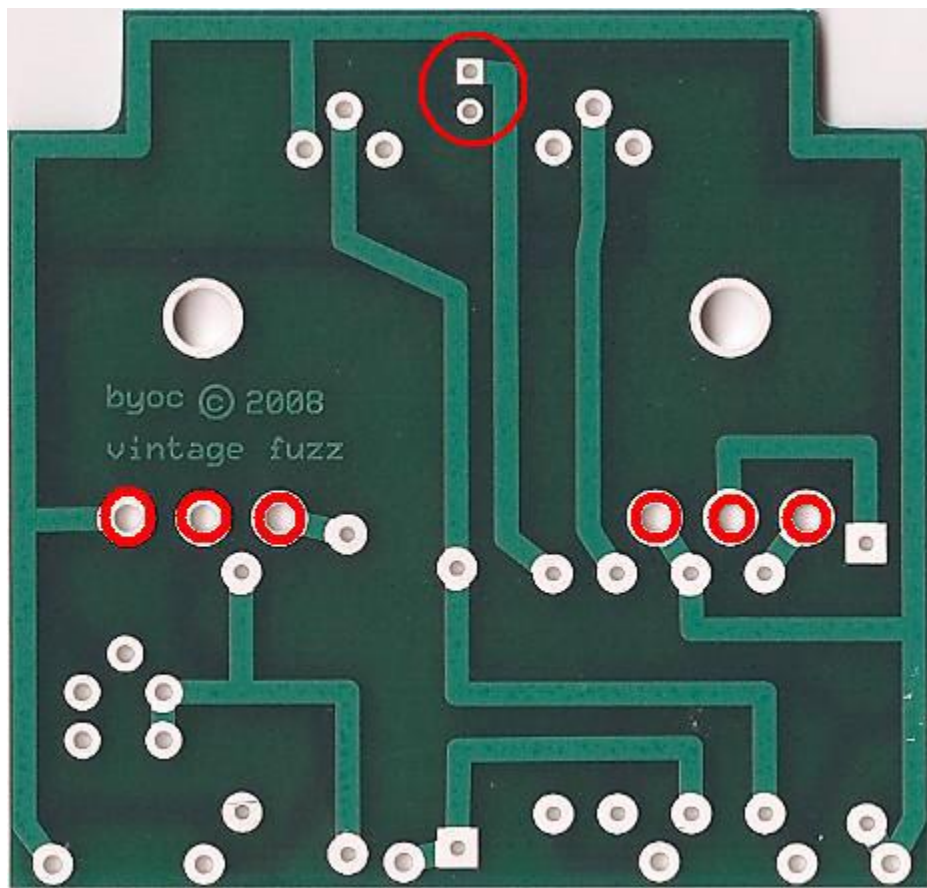

**Step 2: Install the LED but do not solder it or clip the leads.** You will insert the LED into its eyelets. Make sure the longer lead goes in the round eyelet and the shorter lead goes in the square eyelet. Yes this is correct! Longer lead in the round eyelet. Shorter lead in the square eyelet. Now bend the leads of the LED so that it will not fall out of the PCB when you flip it over.

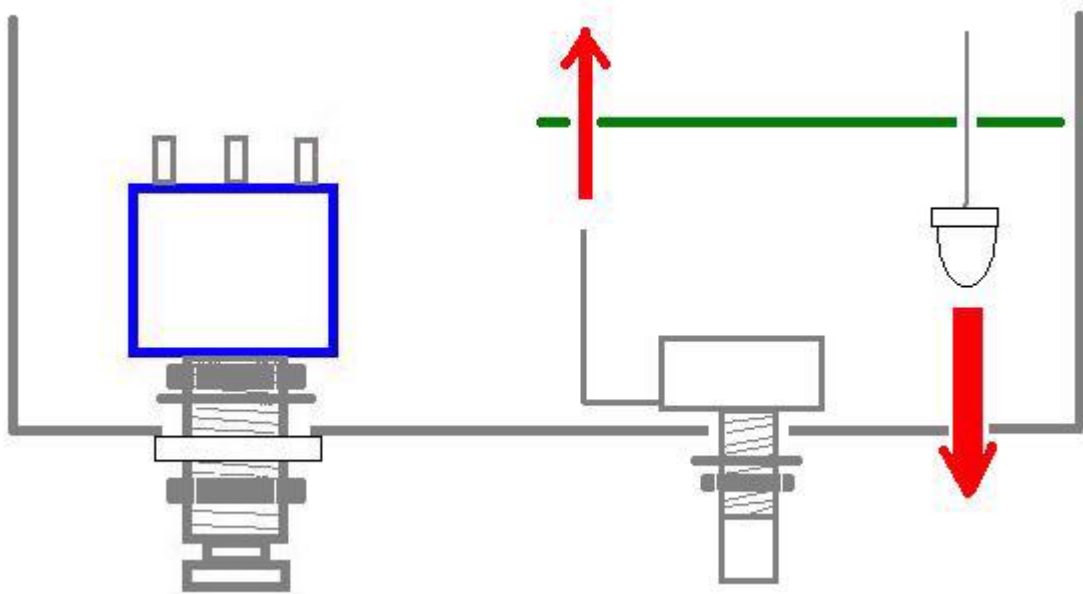

**Step 3:** Now mount the PCB with LED onto the leads of the potentiometers. This move may take a little finesse. It's best to leave your pots somewhat loosely mounted to the enclosure so that you can easily move them to line up with the eyelets on the PCB. You may need to bend the leads of the pots into place if they were bent in shipping.

**Step 4:** once you have the PCB in place, snug the nuts of the pots and toggle switch with your fingers.

**Step 5:** Move the LED into place by guiding it with the leads that are sticking out of the top side of the PCB.

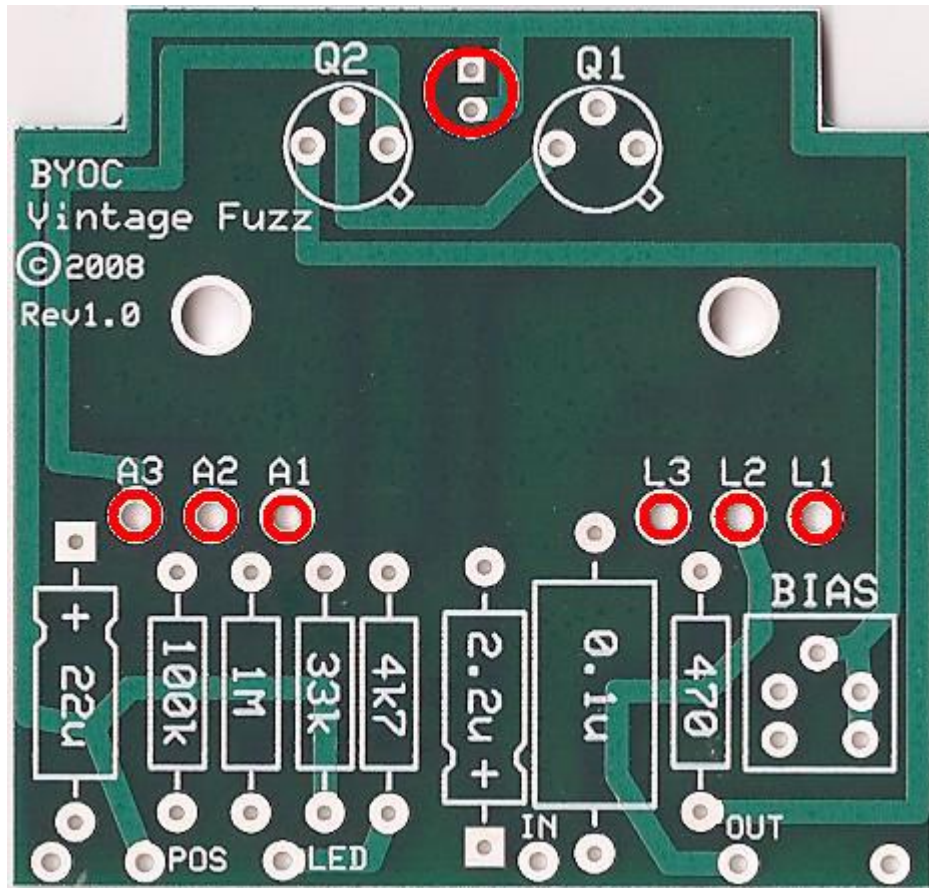

**Step 6:** Solder the LED and pots on the top side of the PCB. Clip the excess LED leads. Do not clip the leads of the pots.

**Solder Lugged Pots: Some kits may come with panel mounted pots with solder lug termination. If your kit has these style pots, follow these steps for mounting the PCB.**

Step 1: Connect the pots to their eyelets on the PCB with hook up wire. Insert the wires from the underside of the PCB and solder on the topside. Lug 1 of the A500k LEVEL pot goes to the L1 eyelet. Lug 2 of the LEVEL pot goes to the L2 eyelet. Lug 3 of the LEVEL pot goes to the L3 eyelet. Lug 1 of the B1k Fuzz pot goes to the A1 eyelet. Lug 2 of the Fuzz pot goes to the A2 eyelet. Lug 3 of the Fuzz pot goes to the A3 eyelet.

Step 2: Install the self-adhesive nylon standoffs from the underside of the PCB into the large mounting eyelets, but do not remove the paper backings yet.

Step 3: Install the LED into the underside of the PCB, but **DO NOT SOLDER IT YET!** The longer lead goes in the round pad and the shorter lead goes in the square pad. Not that's not a typo. Yes that is correct. Longer lead in the round pad. Shorter lead in the

square pad. Bend the leads of the LED outward on the topside of the PCB so that it does not fall out when you flip it over.

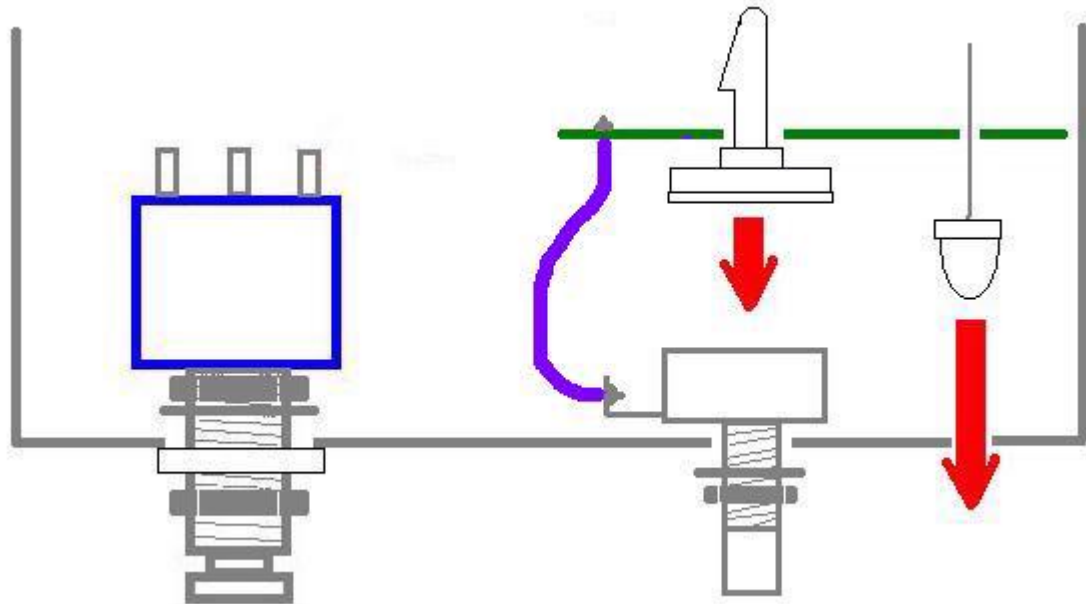

Step 4: Now remove the paper backings from the standoffs and adhere them to the backs of the pots. It's a good idea to clean the backs of your pots with some rubbing alcohol first.

Step 5: Grab the LED by the leads that are sticking out of the topside of the PCB and guide it into place. Solder it from the topside and clip the excess leads.

# Wiring

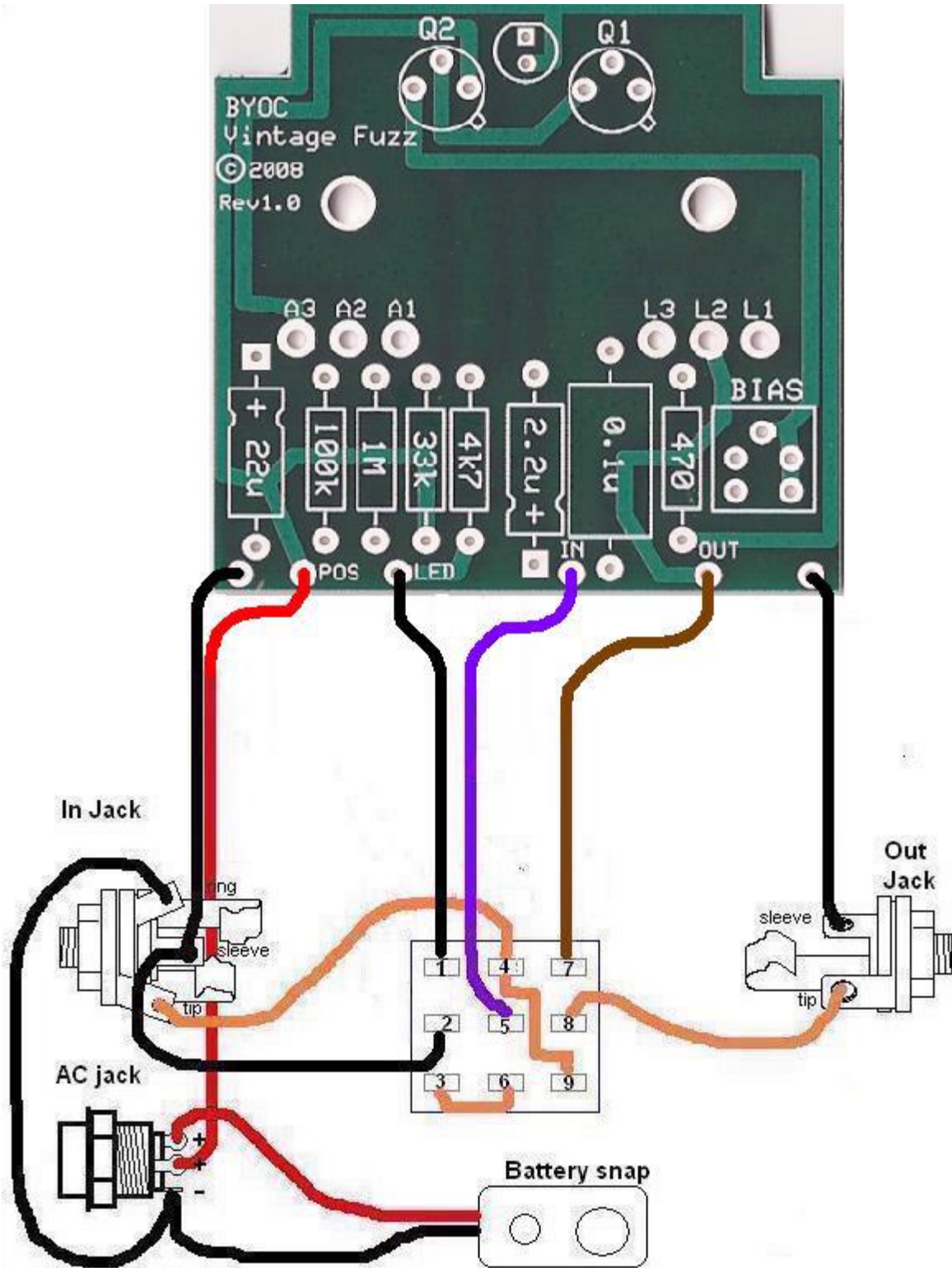

# Finishing Touches

Step 1: Install the transistors

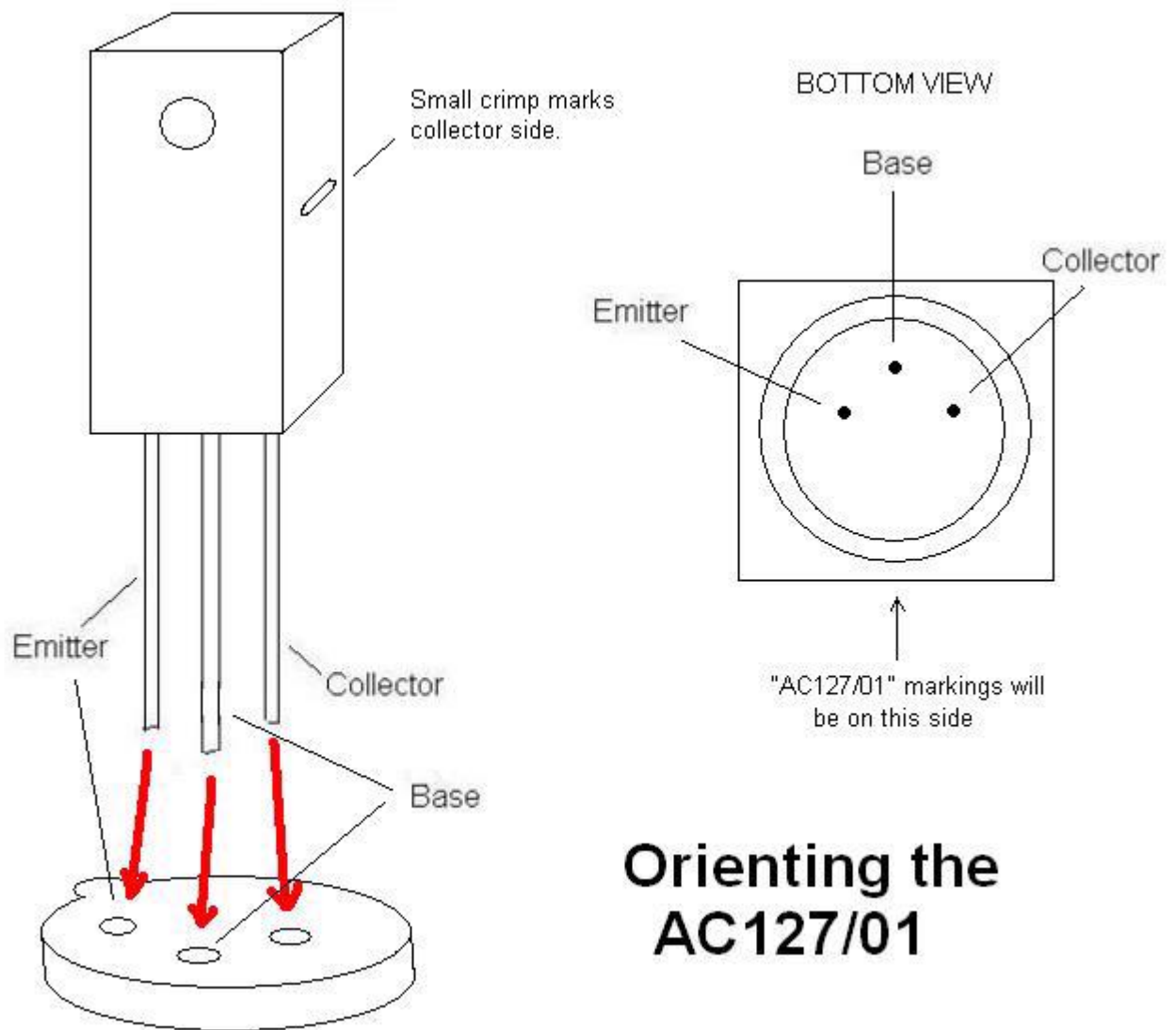

Install the transistors. Do not solder the transistors. Simply push the lead wires into the appropriate socket holes. The transistor socket hole with the tab next to it will be the

emitter. The lead wires on the germanium transistors will be rather long, so you will want to clip off the excess. But be sure to leave enough so you can bend the transistor down and out of the way when you seal the enclosure. But do not clip the transistor leads until you have tested your pedal and know that they work.

### Step 2: Adjusting the bias trimpot

There is no special trick to this. Simply turn the trimpot till it sounds good to you. Usually right in the middle is about where you want it. Some people say that you must set the bias so that the collector of Q2 measures 4.5 - 5.5v, but this is only a matter of opinion. Trust your ears for this step.

### Step 3: Close it up.

Install the base of the enclosure with the 4 screws that came with your kit. Add the rubber bumper feet...unless you're a velcro person. If you've got any problems that you can't figure out yourself, visit [board.buildyourownclone.com](http://board.buildyourownclone.com) for technical support

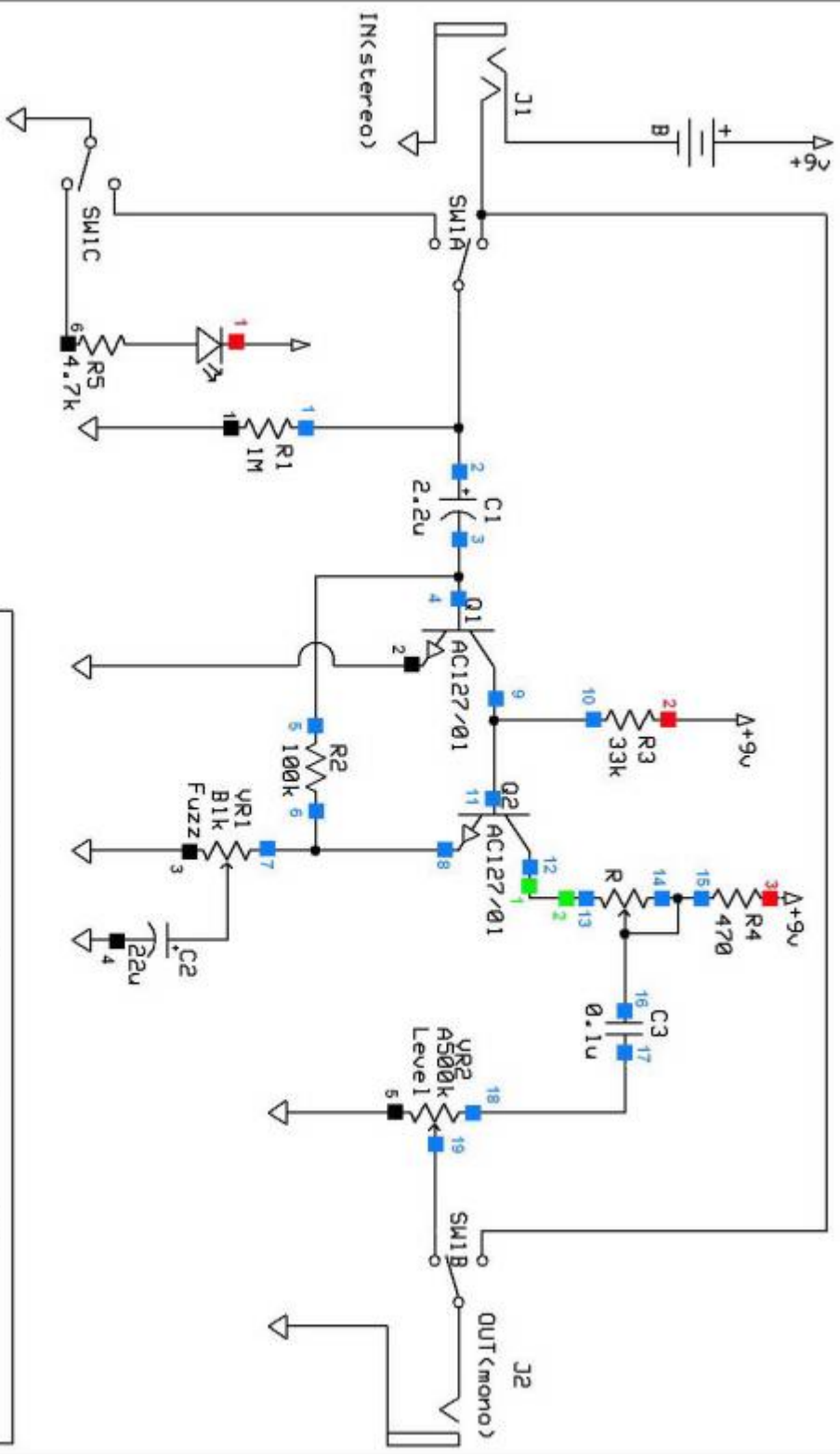

# Build Your Own Clone

## E.S.Y. FUZZ

drawn by:  
K. vanderhullis

Rev 1.0  
3/10/2008

©2008 B.Y.O.C., LLC



## Checking your wiring

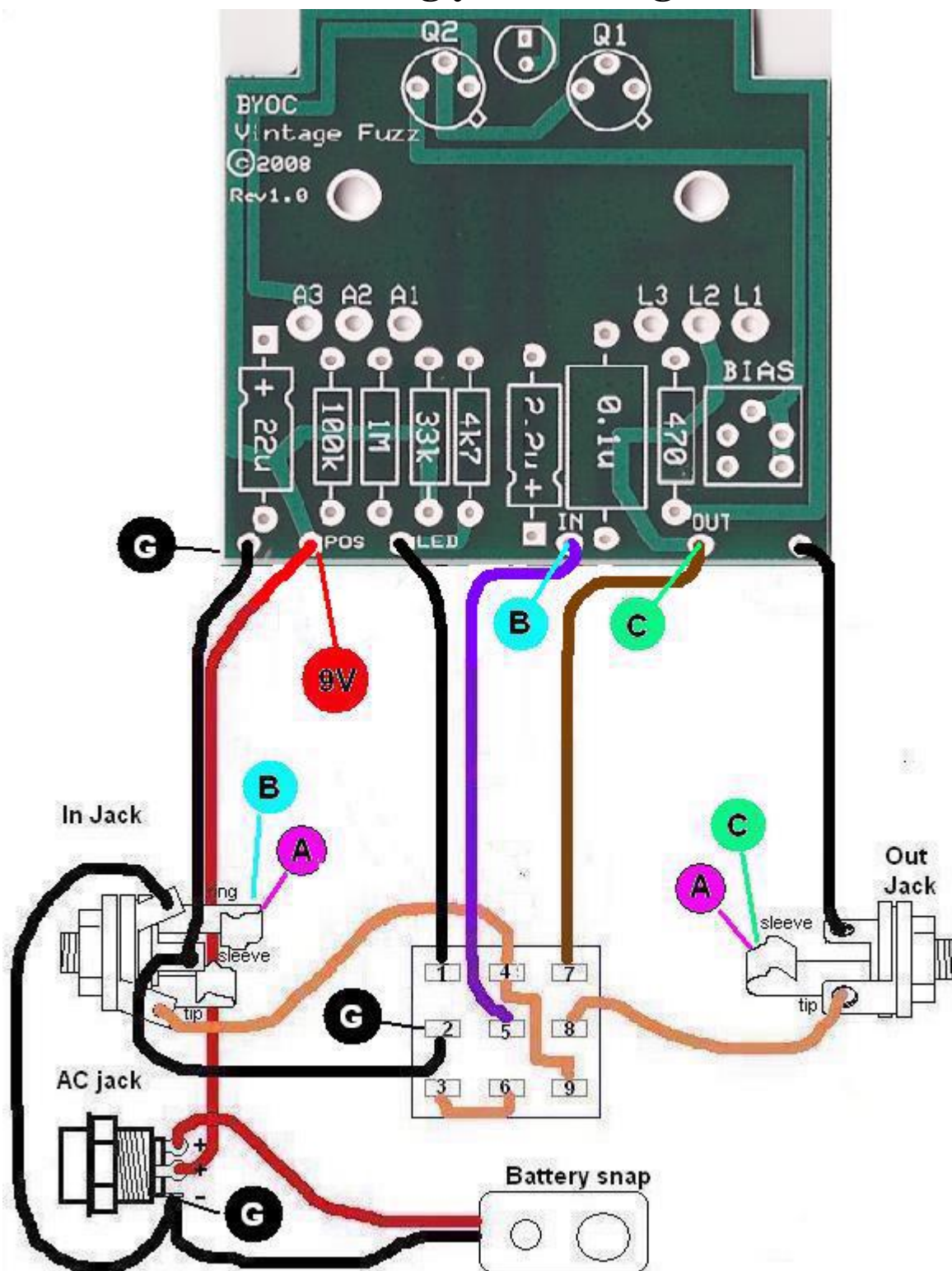

**1. NO POWER:** If you have a completely dead pedal and your LED will not light up, this is usually a good sign that you are not getting power to the circuit. First you need to make sure that you are using a fresh battery or good power supply. Also make sure you have a plug in the IN jack. This acts as your power switch. Now let's make sure you have a good ground. Set your Digital MultiMeter to test for continuity. Continuity is the setting where the meter makes a noise when you touch the two probes together. Now test the "G" locations in the wiring diagram and make sure that there is continuity between all.

**\*If you don't get continuity between all 3 locations, you likely have a bad connection somewhere in the black wire.**

Now set your meter to test for 9VDC. Make sure you do not set it to test for AC. And if you do not have an auto-ranging meter you will need to set it for the proper voltage. You want to set it to test for the lowest voltage without going under 9V. This will probably be 20V on most meters. With the pedal/footswitch in the engaged position, you should get approximately 9VDC when you touch the red probe to the POS eyelet and the black probe to the LED eyelet. You will probably get a little more than 9V with an adaptor and a little less than 9V with a battery.

If you are not getting a reading here, keep the red probe on the POS eyelet and move the black probe to one of the "G" locations.

**\*If you do not get a reading now, you likely have a bad connection somewhere along the red wire.**

If you don't get a 9V reading at the POS and LED eyelets, but you do get a 9V reading at the POS eyelet and one of the "G" locations, there is a possibility that you have a faulty footswitch or a bad connection at lugs 1 and/or 2 of the footswitch. Test for continuity between lugs one and two of the footswitch. Make sure to press the footswitch on and off so that you are certain that you are engaging the throw between lugs 1 and 2 one way or the other.

**\*If you are getting continuity between lugs 1 and 2, then you likely have a bad solder joint at lugs 1, 2, and/or the LED solder pad.**

**\*If you are not getting continuity between lugs 1 and 2 regardless of what state the footswitch is in, then you likely have a faulty footswitch.**

**2. NO BYPASS:** Set your DMM to test for continuity. Touch the probes to the "A" locations which would be the TIPS of the 1/4" jacks. When your footswitch is in the bypass state, you should have continuity between the two "A" locations. Test lugs 8 and 9 of the footswitch for continuity.

**\*If you get continuity between lugs 8 and 9, but no continuity between the 2 "A" locations, then you likely have a bad solder joint somewhere along the orange wiring. This also includes the jumper connection between lugs 4 and 9.**

**\*If you do not get continuity between lugs 8 and 9 and you are certain that the footswitch is in the bypass state, then you likely have a faulty footswitch.**

**3. BYPASS WORKS, BUT THE EFFECT DOES NOT:** This could be any number of problems located on the PBC, but let's check your offboard wiring first and make sure that you are getting signal to and from the PCB to rule that problem out. Set your DMM to test for continuity. Make sure your footswitch is in the "ENGAGED" state. You should get continuity between the two "B" locations and between the two "C" locations. If you do not get continuity between the "B" locations, check for continuity between lugs 4 and 5. If you do not get continuity between the "C" locations, check for continuity between lugs 7 and 8,

- \*If you get continuity between lugs 4 and 5, but no continuity between the "B" locations, then you likely have a bad solder joint along the purple wire.**
- \*If you get continuity between lugs 7 and 8, but no continuity between the "C" locations, then you likely have a bad solder joint along the brown wire.**
- \*If you don't get continuity between lugs 4 and 5, or lugs 7 and 8, and you are certain that your footswitch is in the engaged state, then you likely have a faulty footswitch.**

## Checking your PCB

Ok....So Now you know bypass is working, signal is getting to and from the PCB, and that the PCB also has a connection to +9V and ground. If you're still having trouble, it's time to check your work on the PCB. Keep in mind that the PCB is simply a means of connecting one component or wire to another component or wire. So when you touch your probe to the test location, you want to touch the probe to the exposed component or wire lead at that location and not to the PCB solder pad.

**1. Check all ground connections.** Set your DMM to test for continuity. Touch one probe to the sleeve of either jack and touch the other probe to the various “BLACK” test locations on the PCB. Your DMM should make a buzzing sound.

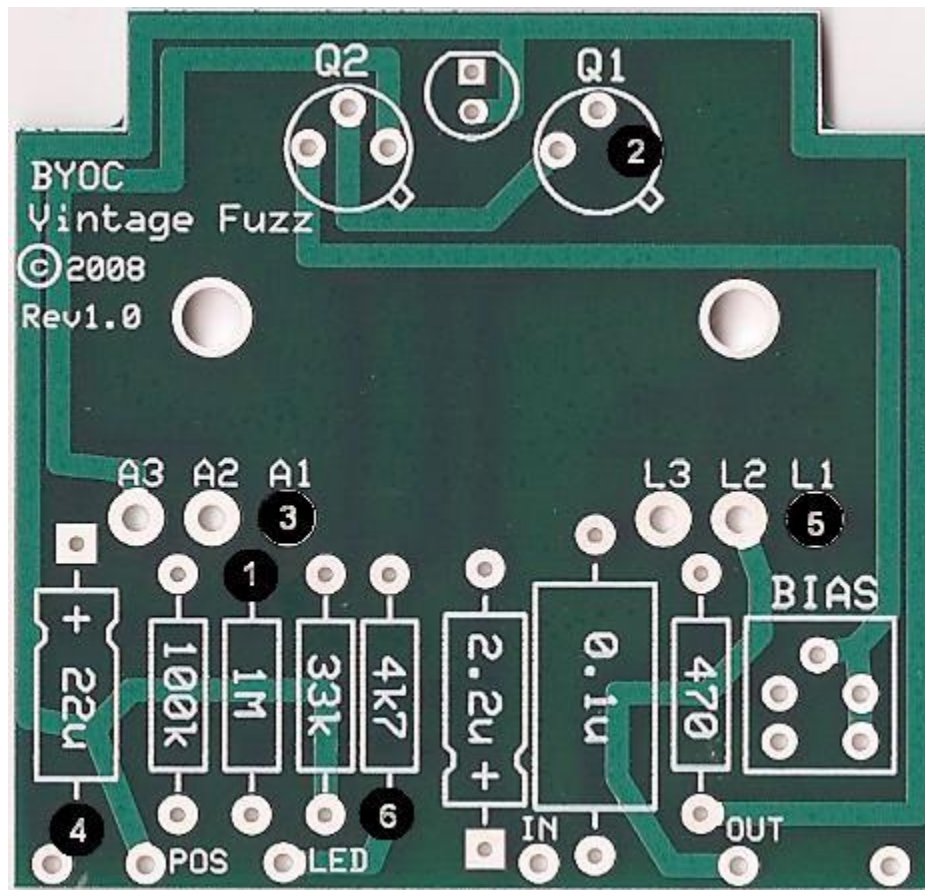

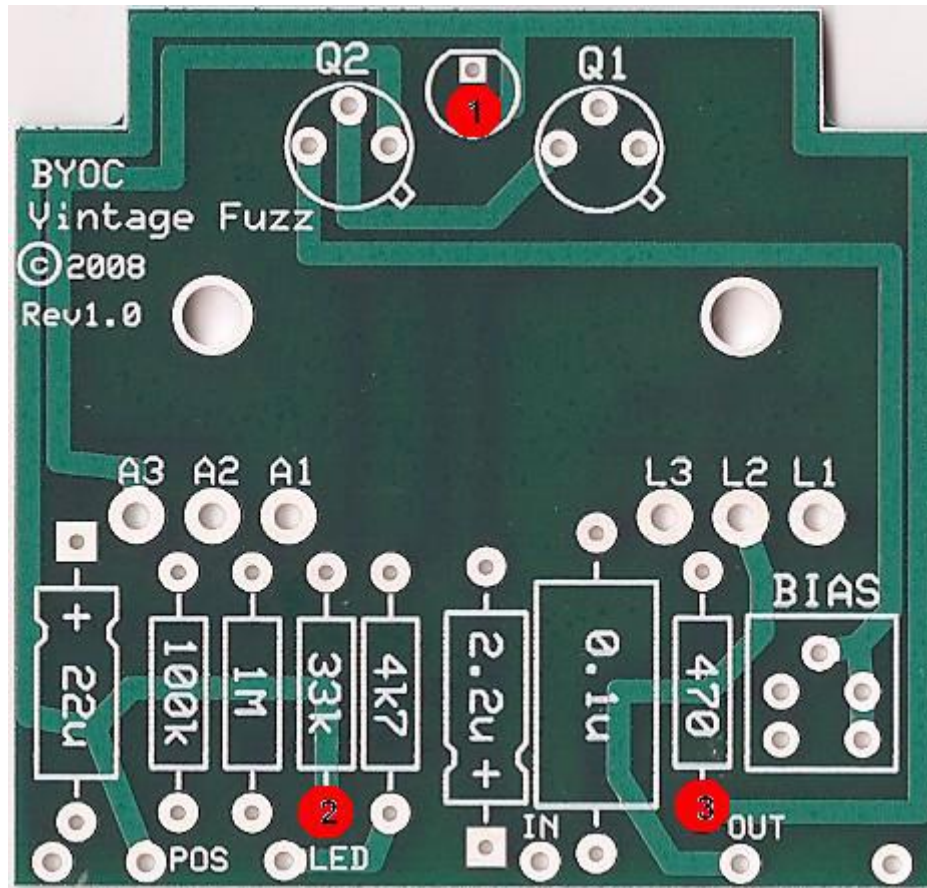

**2. Check all Positive Voltage connections.** Set your DMM to test for 9VDC. Touch the black probe to the sleeve of either jack. Touch the red probe to the various “RED” test locations on the PCB. You should get +9V or exactly the same as what ever you power supply is measuring.

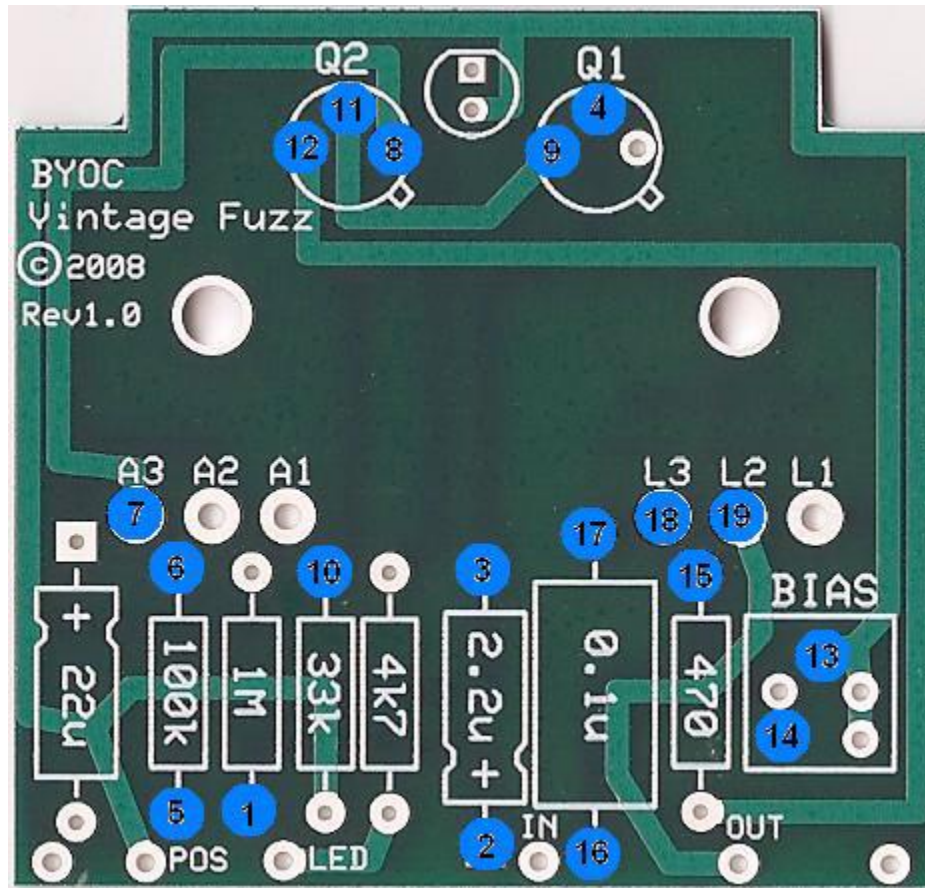

**4. Test the audio signal path.** Do this using a Signal Test Probe. If the audio signal stops at BLUE8, then you likely have a problem with Q1. If it stops at Blue11, you likely have a problem at Q2. You should notice a large volume boost at BLUE9 and deminished volume at BLUE 6 - 8 when compared to BLUE1 - 5. You should notice “fuzz” at BLUE12 and all points there after.

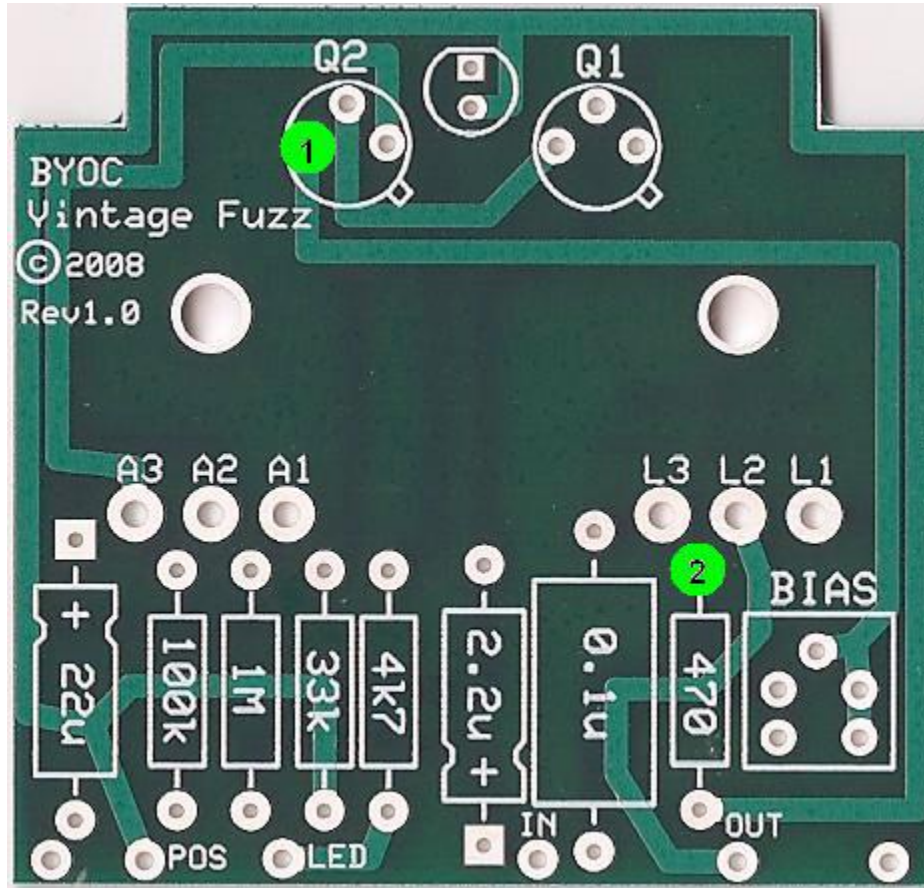

**5. Check the Q2Collector Bias.** Set your DMM to test for 9VDC. Touch the black probe to the sleeve of either jack. Touch the red probe to the green test points. Typically you should see somewhere around 4.5v - 5.5v. But optimal tone may be anywhere between 3.5v and 6.5v. If you cannot get your voltage within this range by adjusting the trimpot you have a problem somewhere.

©2008 byoc, LLC

## Installing the Test Transistor

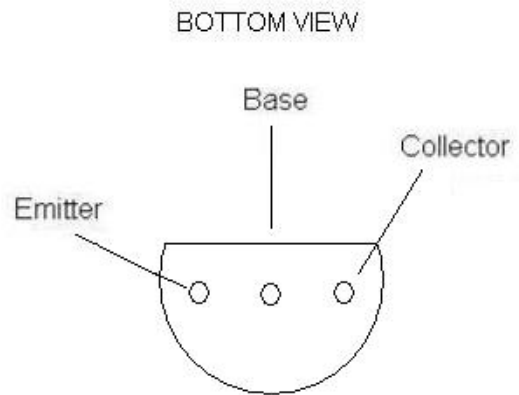
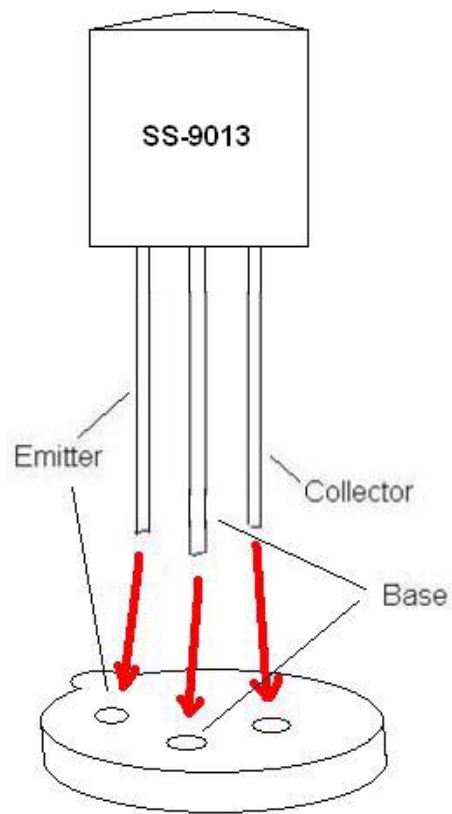

## Orienting the SS-9013