

# **Lazy Sprocket Kit Instructions**

<b>Parts Checklist.....</b>	<b>page 2</b>
<b>Schematic.....</b>	<b>page 3</b>
<b>Populating the Circuit Board.....</b>	<b>page 4 - 8</b>
<b>Assembly.....</b>	<b>page 9</b>
<b>Wiring.....</b>	<b>page 10 - 12</b>
<b>Finish up.....</b>	<b>page 13</b>

# The Lazy Sprocket (a.k.a. true bypass Boss SG-1)

drawn by b.y.o.c.

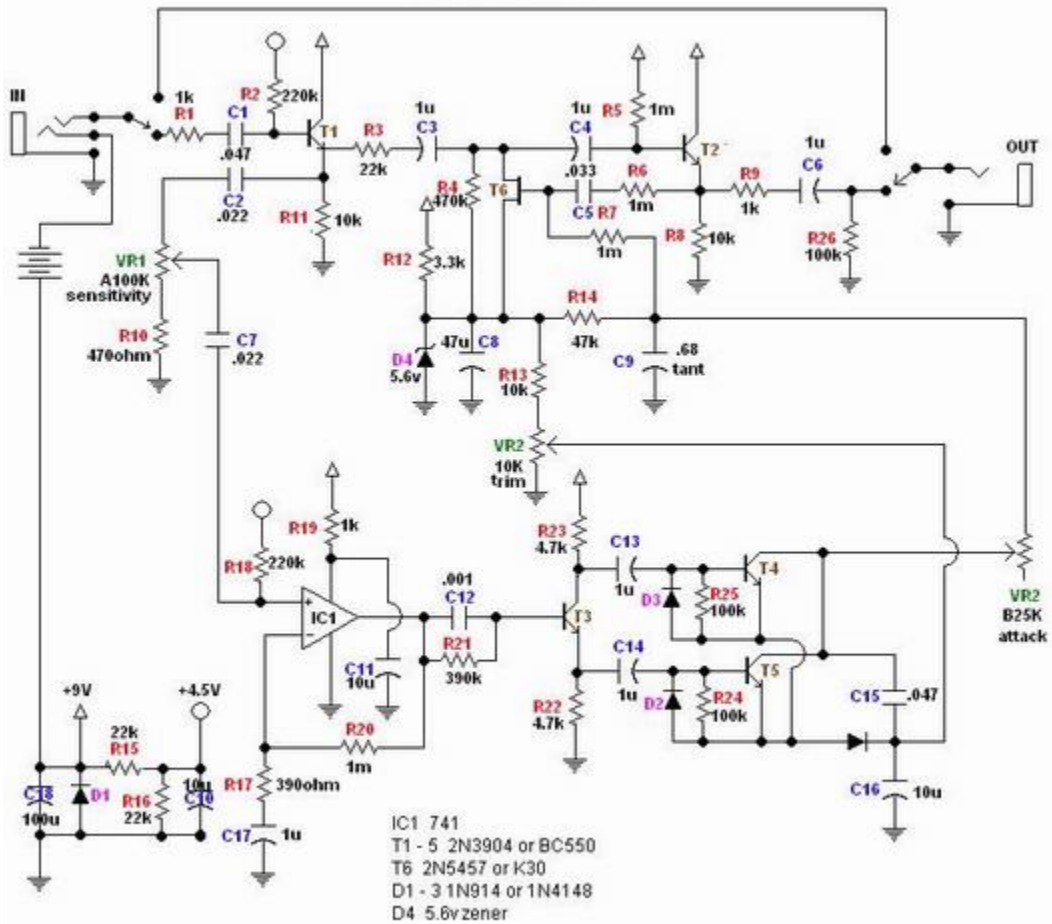

## Parts Checklist for The Lazy Sprocket Kit

### Resistors:

- 1 - 390ohm (orange/white/brown/gold)
- 1 - 470ohm (yellow/purple/brown/gold)
- 3 - 1k (brown/black/red/gold)
- 1 - 3.3k (orange/orange.red/gold)
- 3 - 4.7k (yellow/purple/red/gold)
- 3 - 10k (brown/black/orange/gold)
- 3 - 22k (red/red/orange/gold)
- 1 - 47k (yellow/purple/orange/gold)
- 3 - 100k (brown/black/yellow/gold)
- 2 - 220k (red/red/yellow/gold)
- 1 - 390k (orange/white/yellow/gold)
- 1 - 470k (yellow/purple/yellow/gold)
- 4 - 1M (brown/black/green/gold)

### Capacitors:

- 1 - .001uf film (102)
- 2 - .022uf film (223)
- 1 - .033uf film (333)
- 2 - .047uf film (473)
- 1 - .68 tantalum
- 6 - 1uf aluminum electrolytic
- 3 - 10uf aluminum electrolytic
- 1 - 47uf aluminum electrolytic
- 1 - 100uf aluminum electrolytic

### IC:

- 1 - 741 or TL071 single op amp

### Transistors:

- 5 - 2n3904
- 1 - 2n5457
- 1 - K30

### Diodes:

- 4 - 1N914 or 1N4148(smaller diodes)
- 1 - 5.6v zener (larger diode)

### Potentiometers:

- 1 - 10 trim pot
- 1 - A100K Audio pot "sensitivity"
- 1 - B25k Linear pot "attack"

### Hardware:

- 1 - enclosure w/ 4 screws
- 1 - lazy sprocket circuit board
- 1 - 3pdt footswitch
- 2 - knobs
- 1 - AC adaptor jack
- 1 - 1/4" stereo jack
- 1 - 1/4" mono jack
- 1 - battery snap
- 1 - red LED
- 1 - LED bezel
- hook-up wire





## Using the K30 JFET in place of the 2N5457

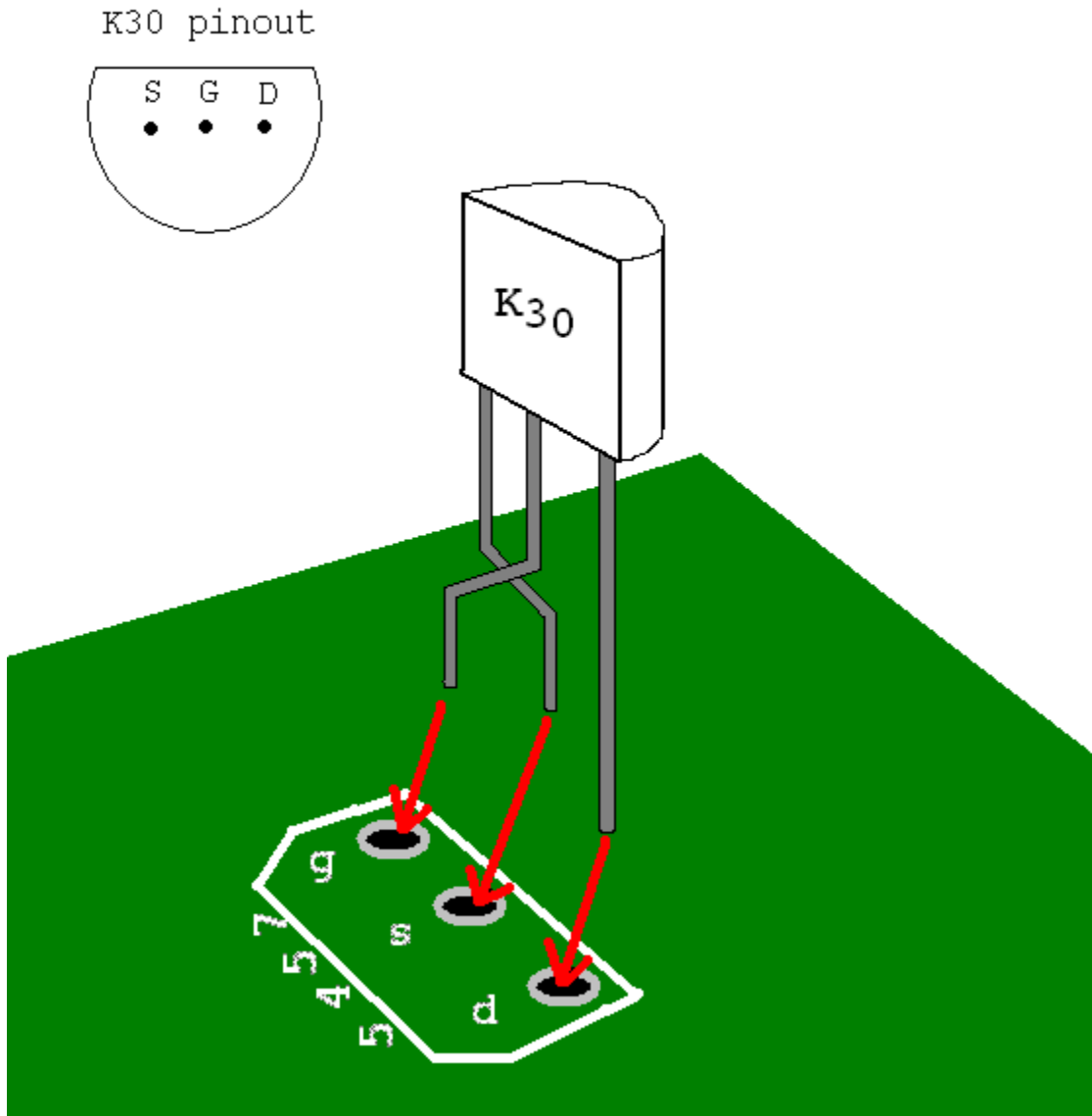

The Lazy Sprocket PCB was designed to use a 2N5457 JFET with a “D-S-G” pinout. The K30 JFET has a “S-G-D” pinout. To use the K30 in place of the 2N5457, insert the K30 so that it is turned 180 degrees. Then cross the left (source) and center (gate) leads so that the gate is now on the left and the source is now in the center.







# Assembly

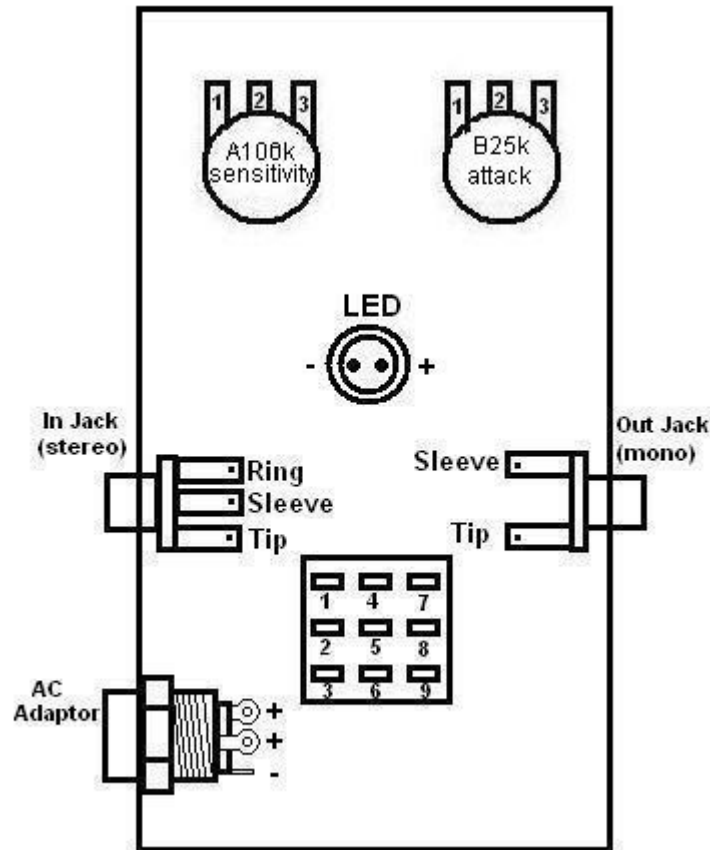

1. Install the jacks first. If you are looking down inside the enclosure, the mono jack goes on the right side and the stereo jack goes on the left. Place the washer on the outside of the enclosure. Use a 1/2" wrench to tighten.
2. Install the AC adaptor jack. The bolt goes on the inside. Use a 3/4" or 14mm wrench to tighten.
3. Install the bezel. The washer and bolt go on the inside. Use a 10mm wrench to tighten.
4. Install the potentiometers so that the solder lugs are pointing down. The 25k (attack) pot goes on the right side and the 100k (sensitivity) pot goes on the left. The washers go on the outside. Use a 10mm wrench to tighten but only snug. Do not over tighten the pots.
5. Install the footswitch. The first bolt and metal washer go inside. The plastic washer and second bolt go on the outside. It does not matter which side you designate as the "leading edge" of the footswitch as long as you orientate it so that the flat sides of the solder lugs are aligned in horizontal rows, not vertical columns.

# Wiring

So many people make the mistake of inserting the LED in through the top of the bezel.  
You insert the LED in through the bottom

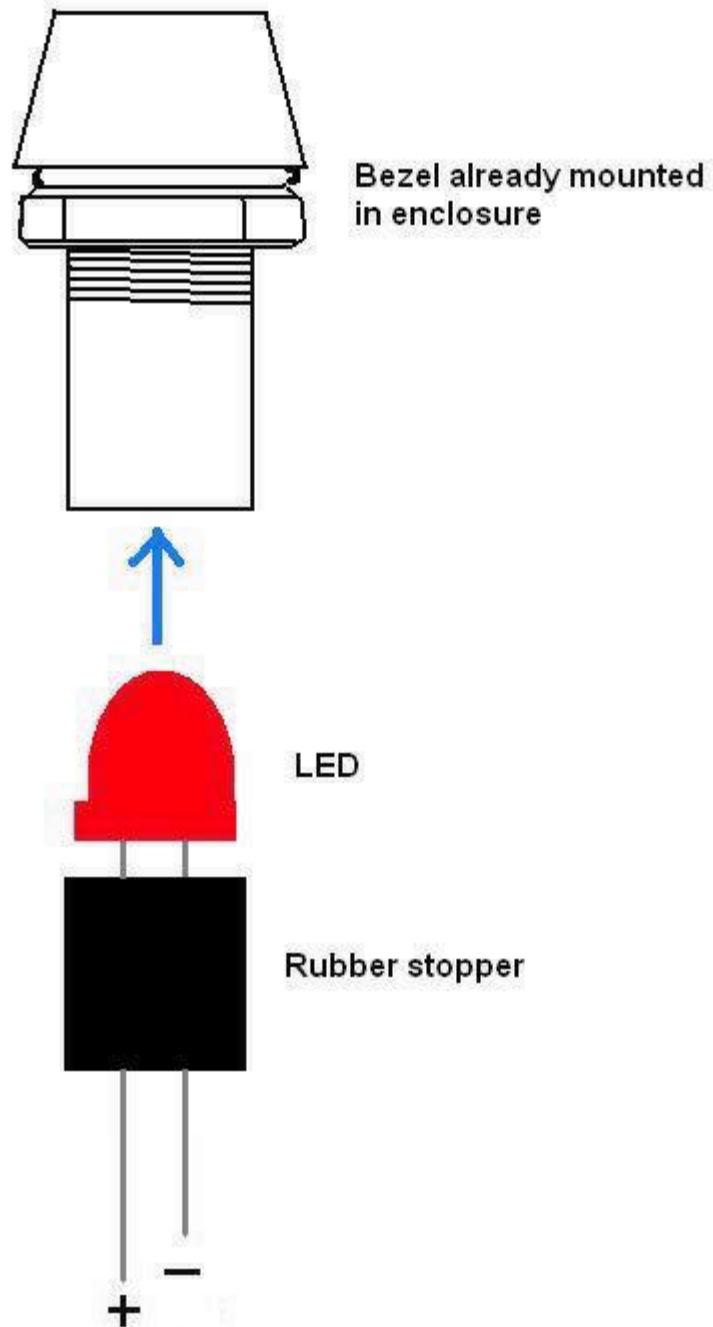

## LED (Light Emitting Diode)

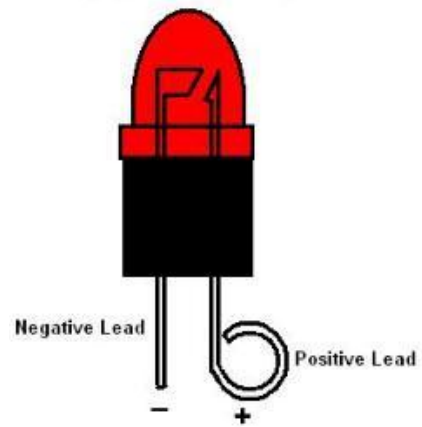

After you mount and install the LED/bezel, Bend the leads of the LED into circles so that you will have something to solder the hookup wire to. DON'T lose track of which lead is negative and positive. The positive lead will be longer. The negative side has a flat side.



## **Finishing Up**

1. Insert the nylon standoffs into the underside of the PCB. Peel off the paper backings and adhere to the back of the pots.
2. Test it out and don't forget to adjust the trimpot as mentioned earlier.
3. Install the base of the enclosure with the 4 screws that came with your kit. Add the rubber bumper feet...unless you're a velcro person.

If you've got any problems that you can't figure out yourself, visit [board.buildyourownclone.com](http://board.buildyourownclone.com) for technical support. Please post pics of you build and include as much detail as possible.