

# BYOC Octave Fuzz Kit Instructions



## **Warranty:**

**BYOC, LLC guarantees that your kit will be complete and that all parts and components will arrive as described, functioning and free of defect. Soldering, clipping, cutting, stripping, or using any of the components in any way voids this guarantee. BYOC, LLC guarantees that the instructions for your kit will be free of any major errors that would cause you to permanently damage any components in your kit, but does not guarantee that the instructions will be free of typos or minor errors. BYOC, LLC does not warranty the completed pedal as a whole functioning unit nor do we warranty any of the individual parts once they have been used. If you have a component that is used, but feel it was defective prior to you using it, we reserve the right to determine whether or not the component was faulty upon arrival. Please direct all warranty issues to:**

**Sales@buildyourownclone.com** this would include any missing parts issues.

## **Return:**

BYOC, LLC accepts returns and exchanges on all products for any reason, as long as they are unused. We do not accept partial kit returns. Returns and exchanges are for the full purchase price less the cost of shipping and/or any promotional pricing. Return shipping is the customer's responsibility. This responsibility not only includes the cost of shipping, but accountability of deliver as well. Please contact sales@buildyourownclone.com to receive a return authorization before mailing.

## **Tech Support:**

BYOC, LLC makes no promises or guarantees that you will successfully complete your kit in a satisfactory manner. Nor does BYOC, LLC promise or guarantee that you will receive any technical support. Purchasing a product from BYOC, LLC does not entitle you to any amount of technical support. BYOC, LLC does not promise or guarantee that any technical support you may receive will be able to resolve any or all issues you may be experiencing.

That being said, we will do our best to help you as much as we can. Our philosophy at BYOC is that we will help you only as much as you are willing to help yourself. We have a wonderful and friendly DIY discussion forum with an entire section devoted to the technical support and modifications of BYOC kits.

[www.buildyourownclone.com/board](http://www.buildyourownclone.com/board)

When posting a tech support thread on the BYOC forum, please post it in the correct lounge, and please title your thread appropriately. If everyone titles their threads "HELP!" it makes it impossible for the people who are helping you to keep track of your progress. A very brief description of your specific problem will do. It will also make it easier to see if someone else is having or has had the same problem as you. The question you are about to ask may already be answered. Here is a list of things that you should include in the body of your tech support thread:

1. A detailed explanation of what the problem is. (Not just, "It doesn't work, help")
2. Pic of the top-side of your PCB.
3. Pic of the underside of your PCB.
4. Pic that clearly shows your footswitch/jack wiring and the wires going to the PCB
5. A pic that clearly shows your wiring going from the PCB to the pots and any other switches(only if your kit has non-PC mounted pots and switches)
6. Is bypass working?
7. Does the LED come on?
8. If you answer yes to 6 and 7, what does the pedal do when it is "on"?
9. Battery or adapter. (If battery, is it good? If adapter, what type?)

Also, please only post pics that are in focus. You're only wasting both parties' time if you post out of focus, low-res pics from your cell phone.

### **Revision Notes:**

Rev 2.1 (current) changed transistors to 2N3906 and 2N3904. Rev 2.0 (previous) No known errors. Go to: <http://byoceletronics.com/octavefuzzinstructions-old.pdf> to download instructions for the previous version of the Octave Fuzz kit.

Rev 1.0 (older version) There are no known errors in this revision.

Go to: <http://www.byoceletronics.com/octavefuzzV1.pdf> to download instructions for the older version of the Octave Fuzz kit.

### **Copyrights:**

All material in this document is copyrighted 2018 by BYOC, LLC

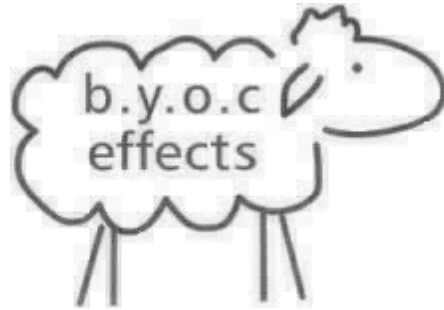

## **OCTAVE FUZZ KIT INSTRUCTION INDEX**

<b>Parts Checklist.....</b>	<b>page 4 - 5</b>
<b>Populating the Circuit Board.....</b>	<b>page 6 - 12</b>
<b>Assembly.....</b>	<b>page 13 - 15</b>
<b>Wiring the Footswitch &amp; Jacks.....</b>	<b>page 16 - 18</b>
<b>Schematic.....</b>	<b>page 19</b>

## Parts Checklist for BYOC Octave Fuzz

### Resistors:

- 1 - 220ohm (red/red/black/black/brown)
- 1 - 470ohm (yellow/purple/black/black/brown)
- 1 - 1k (brown/black/black/brown/brown)
- 1 - 1.2k (brown/red/black/brown/brown)
- 1 - 4.7k (yellow/purple/black/brown/brown)
- 1 - 22k (red/red/black/red/brown)
- 1 - 47k (yellow/purple/black/red/brown)
- 1 - 180k (brown/gray/black/orange/brown)
- 1 - 220k (red/red/black/orange/brown)
- 1 - 680k (blue/gray/black/orange/brown)
- 1 - 820k (gray/red/black/orange/brown)
- 1 - 1M(brown/black/black/yellow/brown)

### Capacitors:

- 1 - 150pf ceramic disc
- 1 - .001 $\mu$ f/1n film (1n0j)
- 1 - 0.1 $\mu$ f/100n film (100nj)
- 2 - 33 $\mu$ f aluminum electrolytic
- 3 - 100 $\mu$ f aluminum electrolytic

### Diodes:

- 1 - 1N4001
- 2 - 1N34A or similar germanium diodes

### Transistors:

- 2 - 2N3904
- 1 - 2N3906

### Transformer:

- 1 - TM022 1.725:1 audio transformer

**Potentiometers: Be sure to snap off the small tab on the side of each panel mounted pot.**

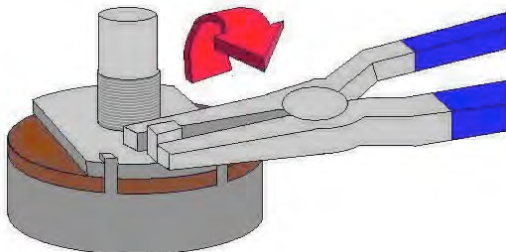

- 1 - B1k (INTENSITY)
- 1 - A100k (VOLUME)

**Hardware:**

- 1 - drilled enclosure w/ 4 screws
- 1 - BYOC Octave Fuzz circuit board
- 1 - SPDT PC mounted toggle switch
- 1 - 3PDT footswitch
- 2 - knobs
- 1 - AC adaptor jack
- 1 - ¼" mono jack
- 1 - ¼" stereo jack
- 1 - red LED
- 1 - battery snap
- hook-up wire

# Populating the Circuit Board

**STEP 1:** Add the resistors. Resistors are not polarized, so it does not matter which end goes in which solder pad.

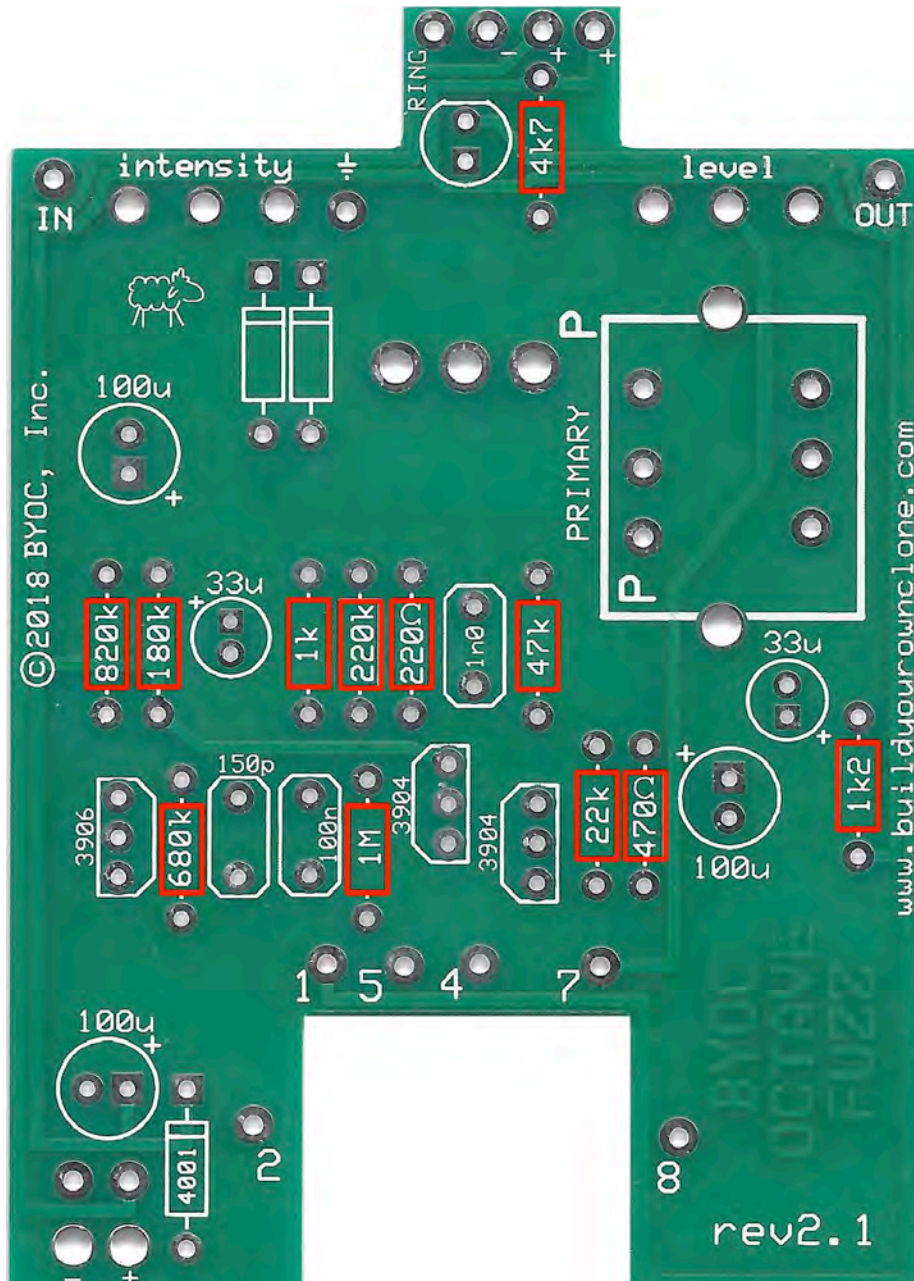

**STEP 2:** Add the diodes. The 1N4001 will be black with a silver stripe and is highlighted in yellow. The Germanium diodes will go in the spots highlighted in red. Be sure to match the end of the diode with the stripe to the layout on the PCB. The stripped end should go in the square solder pad. **If your Germanium diodes have a white and gray stripe on either end, place the end with the gray stripe in the square hole. If your diodes have a single white dot, place the dot side into the round holes.**

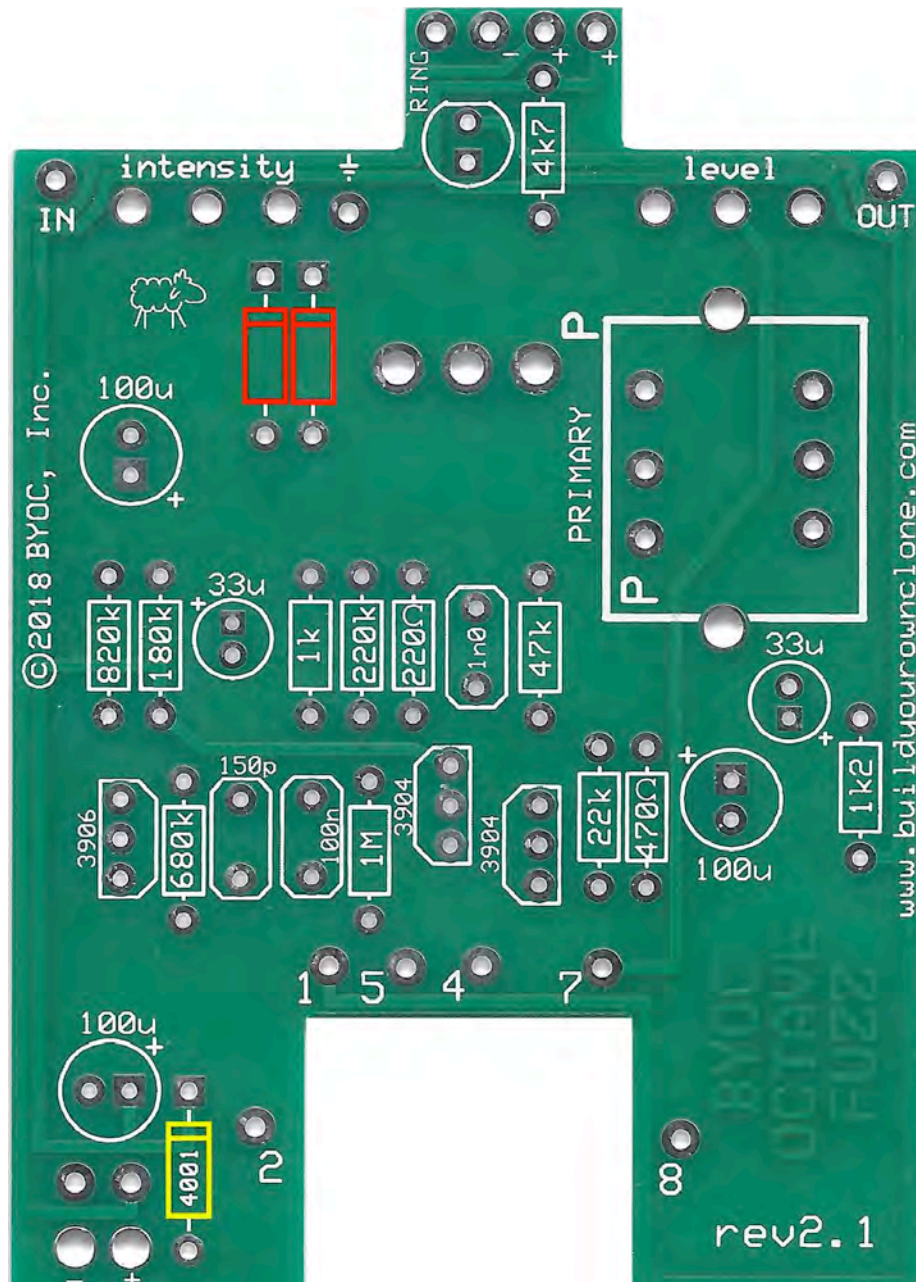

**STEP 3:** Add the film and ceramic disc capacitors. These are not polarized so they can be inserted into the PCB in either direction. The ceramic disc capacitor is highlighted in yellow.

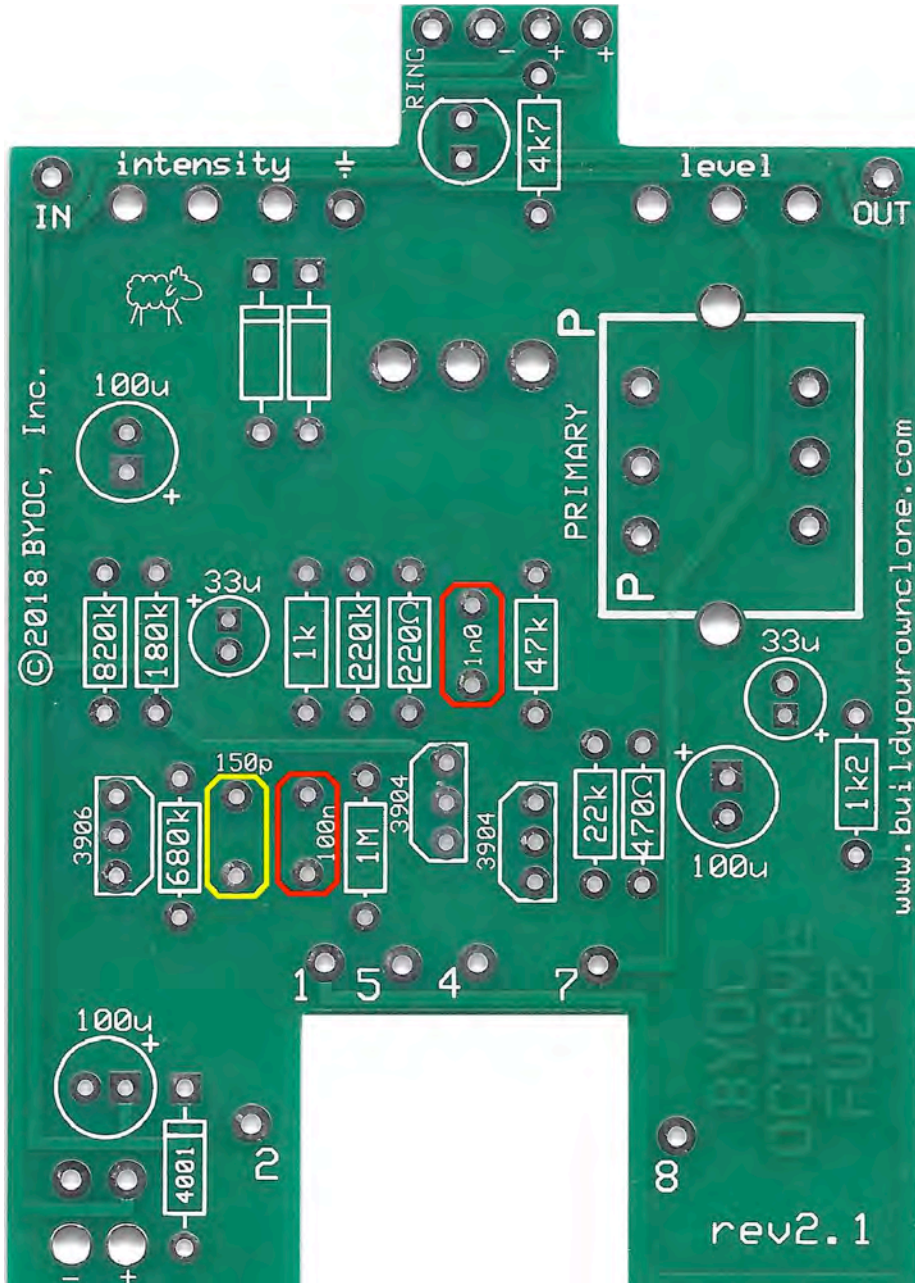



**STEP 4:** Add the transistors. Match the flat side of the transistor to the flat side of the layout on the PCB. The 2N3904 transistors are highlighted in red. The 2N3906 transistor is highlighted in yellow.

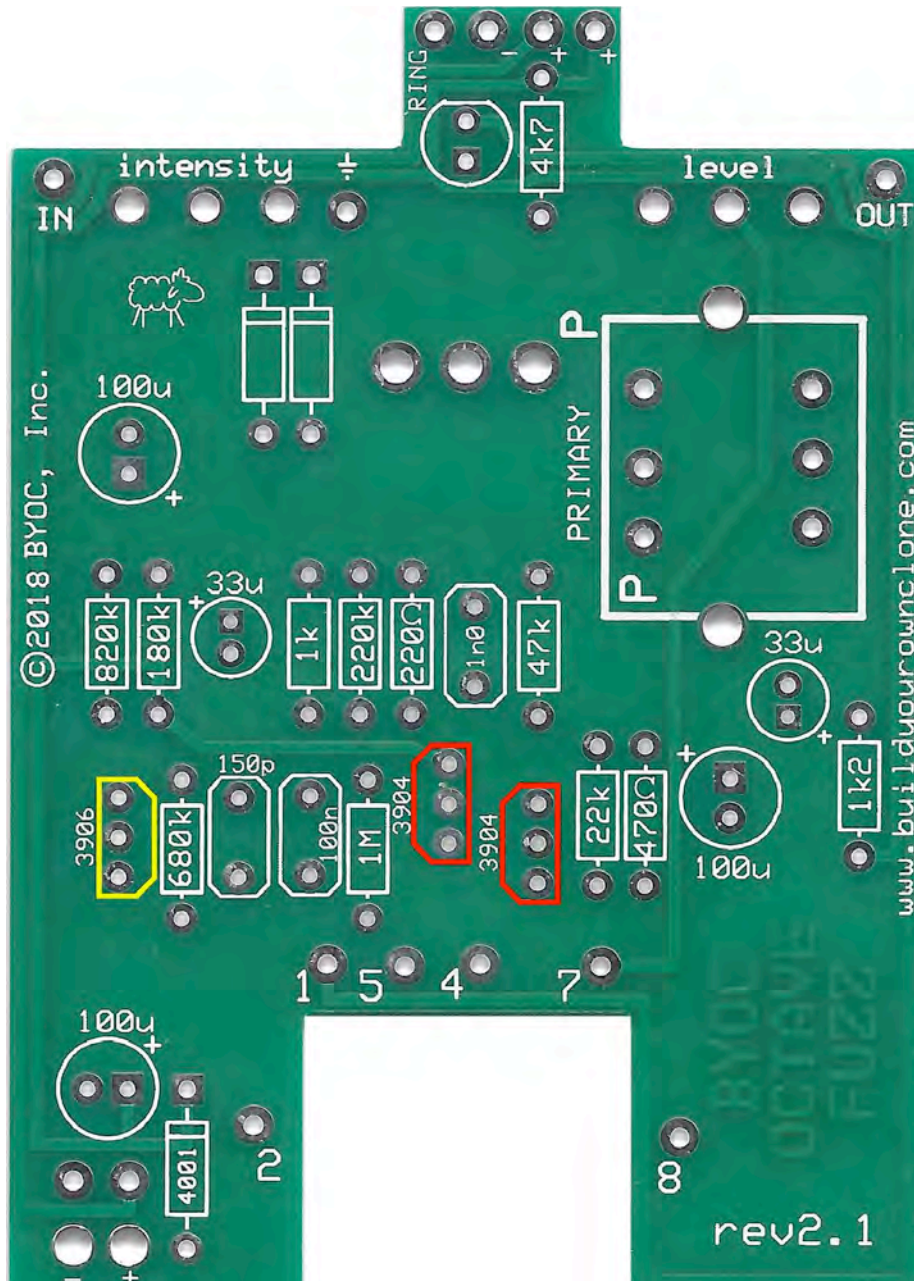

**STEP 5:** Add the aluminum electrolytic capacitors. These are polarized. The positive end will have a longer lead and should go in the square solder pad. The negative end will have a shorter lead with a black strip running down the body of the capacitor.

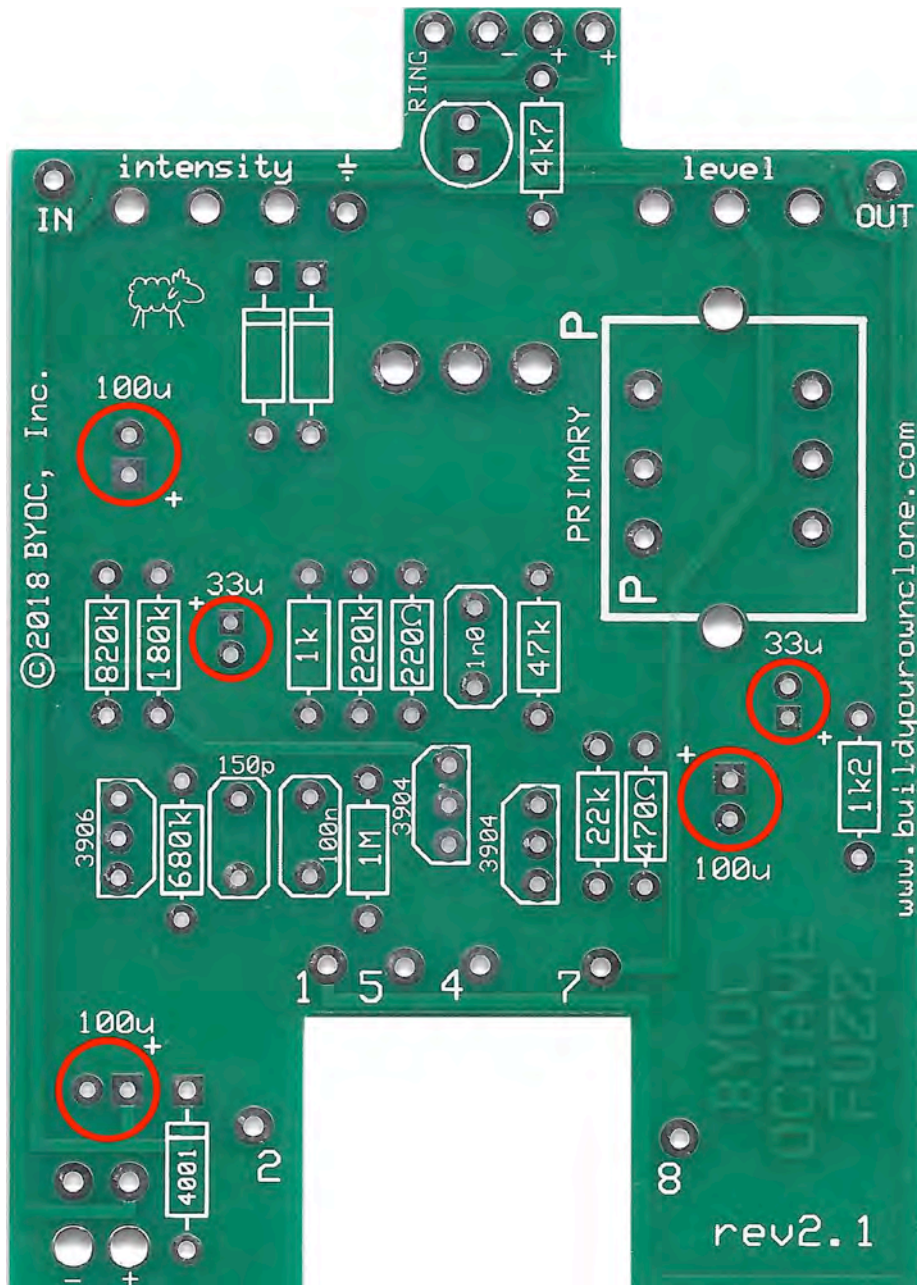

**STEP 6:** Add the transformer. A transformer has a primary and secondary side. The primary side will be labeled with a “P”. Insert the transformer into the PCB so that the primary side matches the PCB.

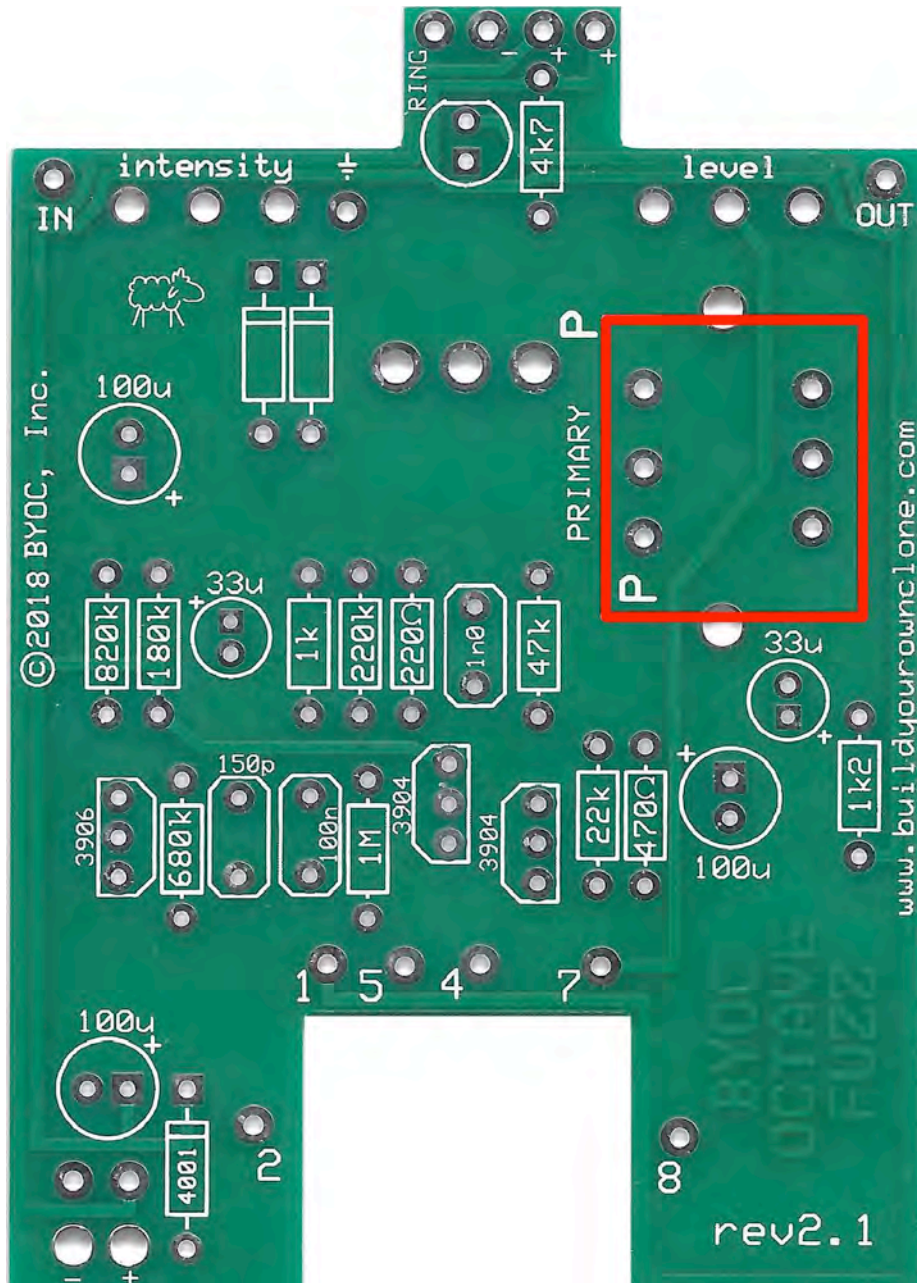

**Step 7:** Add the battery snap. Thread the solder ends of the snap through the under side of the strain relief holes. Insert the stripped ends of the battery snap wires into the topside of their respective solder pads. Remember, the red wire goes in the “+” hole and the black wire goes in the “-” hole.

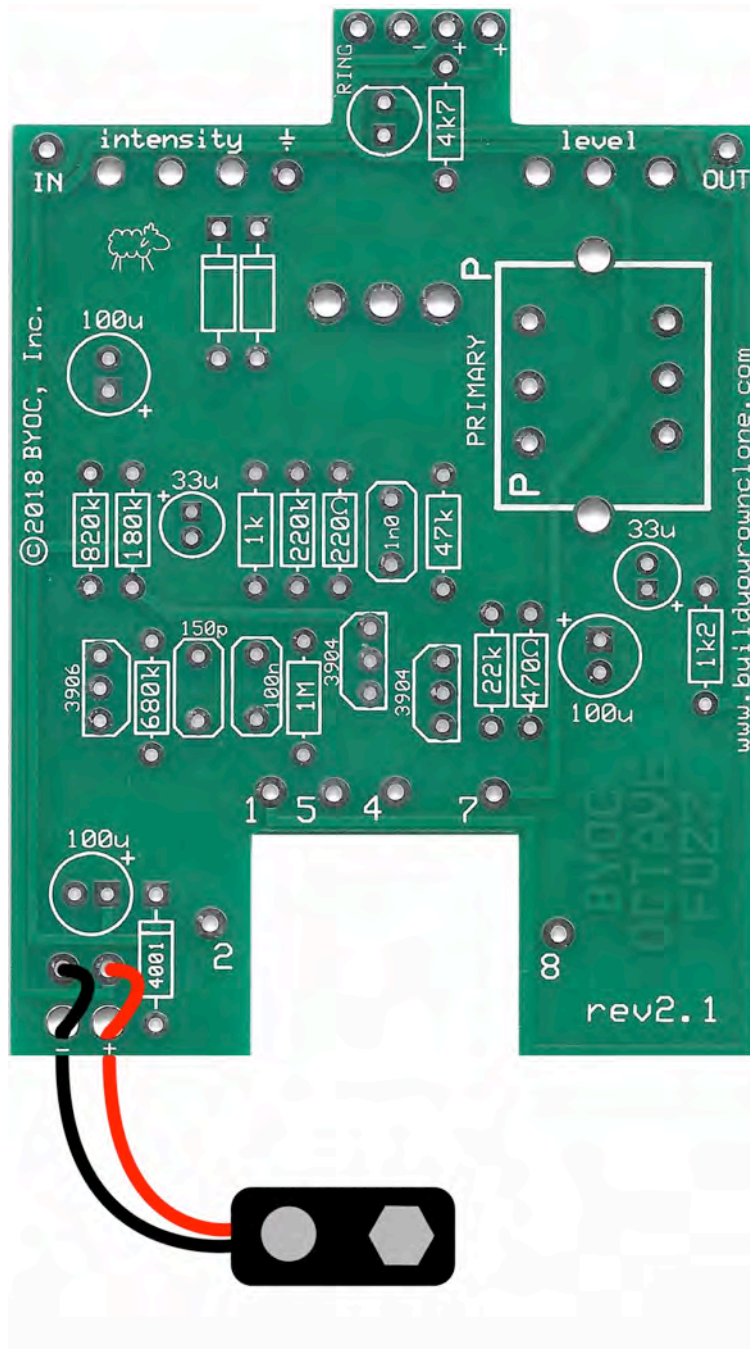

# Assembly

Step 1: Mount the DC adaptor jack to the enclosure.

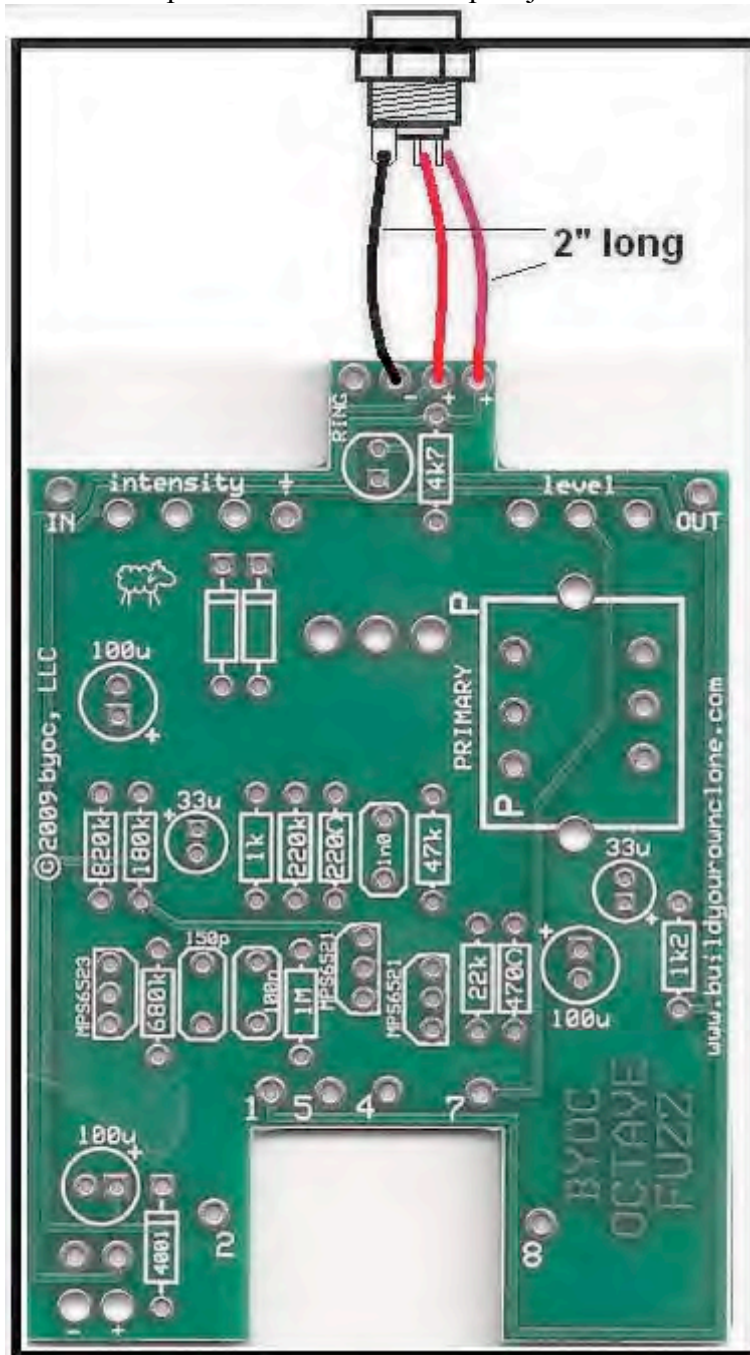

Step 2: Connect the TIP (negative) terminal of the DC adaptor jack to the “-” eyelet on the PCB with 2 inches of hook up wire. Connect the SLEEVE of the DC adaptor jack to the “+” eyelet on the far right side of the PCB with 2 inches of hook up wire. Connect the battery disconnect terminal of the DC adaptor jack to the “+” eyelet more towards the

center of the PCB with 2" of hookup wire.

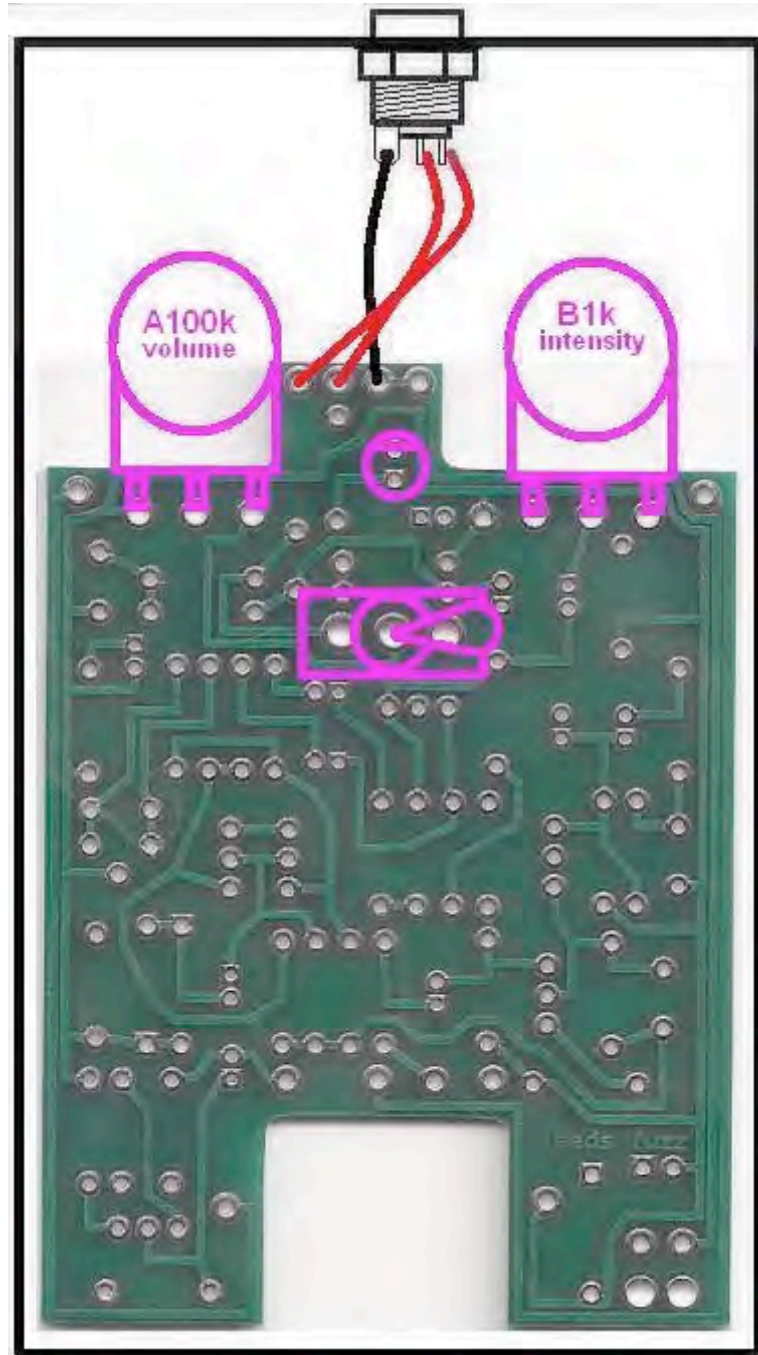

Step 3: Flip the PCB over so that the bottom or solder side is up. Insert the two potentiometers, the LED, and the toggle switch into the bottom side of the PCB. **DO NOT SOLDER!!!** There are only two ways in which the toggle switch can fit into the PCB. Either way is fine. The longer lead of the LED goes in the square solder pad hole and the shorter lead goes in the round solder pad hole.

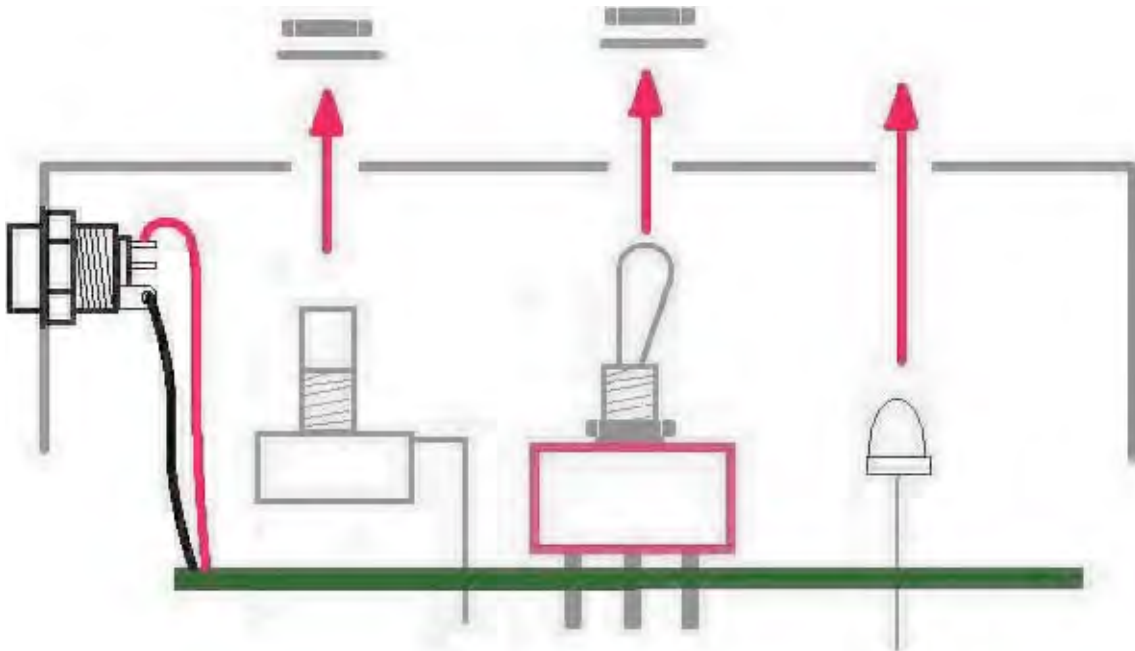

Step 4: Hold the PCB in one hand so that the component side of the PCB is in the palm of your hand and the bottom side with the pots, toggle switch and LED is facing up. Now use your other hand to guide the predrilled enclosure onto the PCB assembly so that the pots, toggle switch and LED all go into their respective holes. Once the PCB assembly is in place, secure it by screwing on the washers and nuts for the pots and toggle switch. Only tighten them with your fingers. You do not want them very tight yet. Be sure to keep your hand on the PCB so that it does not fall off the PCB mounting posts of the pots and toggle switch.

Step 5: Turn the entire pedal over so that the component side of the PCB is facing up. Lift the PCB up off the pots and toggle switch about 2mm just to make sure that the back of the PCB does not short out against those pots. Make sure the PCB is level and symmetrically seated inside the enclosure.

Step 6: Solder the pots, PCB, and LED. You will solder these parts on the component side of the PCB. After you have soldered them in place, be sure to tighten up their nuts.

# Wiring the footswitch, and jacks

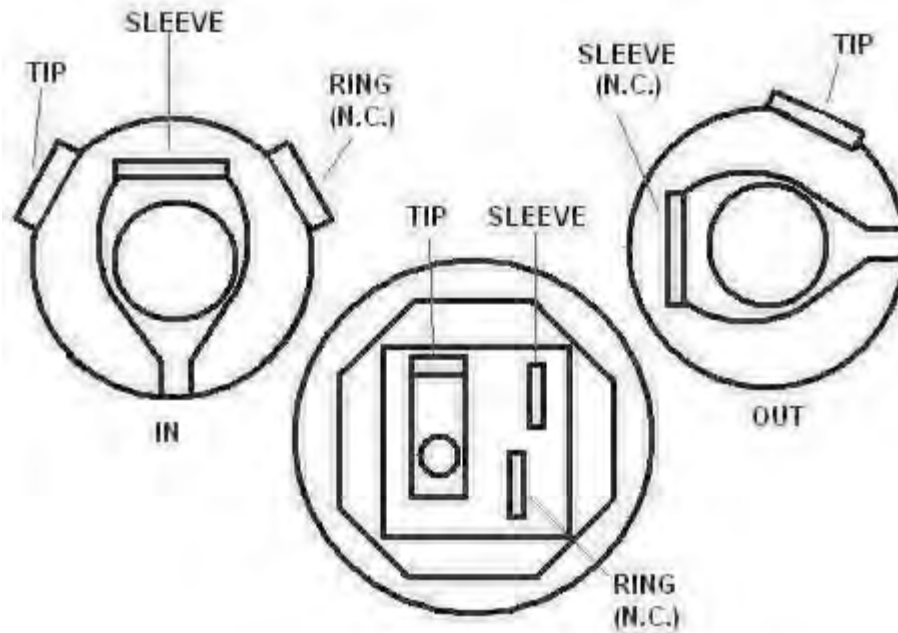

Step 1: Install the 1/4" jacks to the enclosure. Be sure to turn the OUT jack a 1/4 turn counter clockwise so that solder terminal for the tip does not short out against the enclosure.

## Footswitch Solder Lug Designations

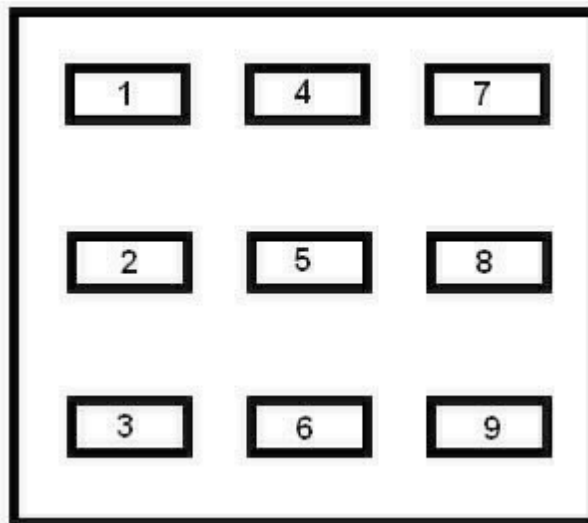



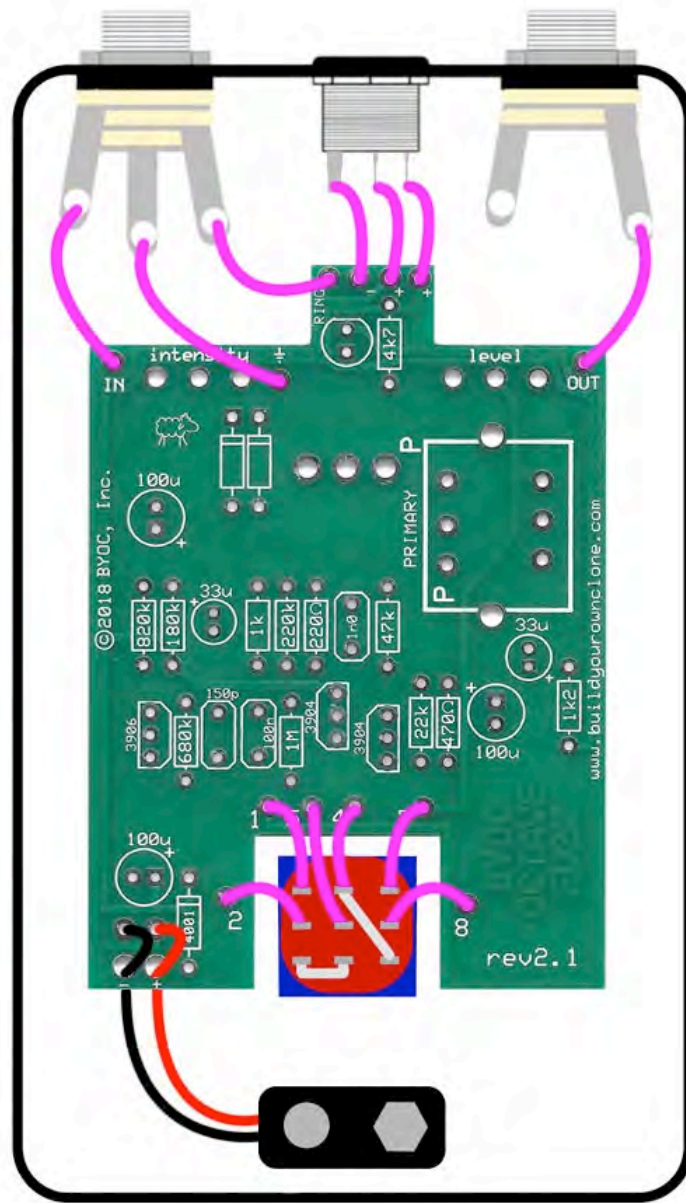

Step 2:

- Cut 4 x 3/4" pieces of wire. Strip 1/8" off each end. These will be used to connect lugs/eyelets 1, 2, 7, & 8
- Cut 1 x 1" piece of wire. Strip 1/8" off each end. This will be used to connect lug/eyelet 5
- Cut 1 x 1.5" piece of wire. Strip 1/8" of one end. Strip 1/2" off the other end. This will be used to connect lug/eyelet 4. The longer stripped end will be used to jumper lug 4 to 9.
- Cut 3 x 2" pieces of wire. Strip 1/4" off each end. These will be used to connect the tip and sleeve of the IN jack and the tip of the OUT jack to the PCB.

- Cut 1 x 1.5” piece of wire. Strip 1/4” off each end. This will be used to connect the ring of the IN jack to the ring eyelet on the PCB.

Step 3: Solder the wires for the footswitch.

Step 4: Remove the PCB assembly from the enclosure. Solder the open ends of the wires that you just soldered to the footswitch to their respective eyelets on the PCB. Load the wires in from the top and solder on the bottom side.

Step 5: Reinstall the PCB assembly to the enclosure. Install the footswitch to the enclosure. It will have a white nylon washer and a silver metal washer. You can decide which washer you want to be visible on the outside of the enclosure.

Step 6. Solder the jacks to the PCB.

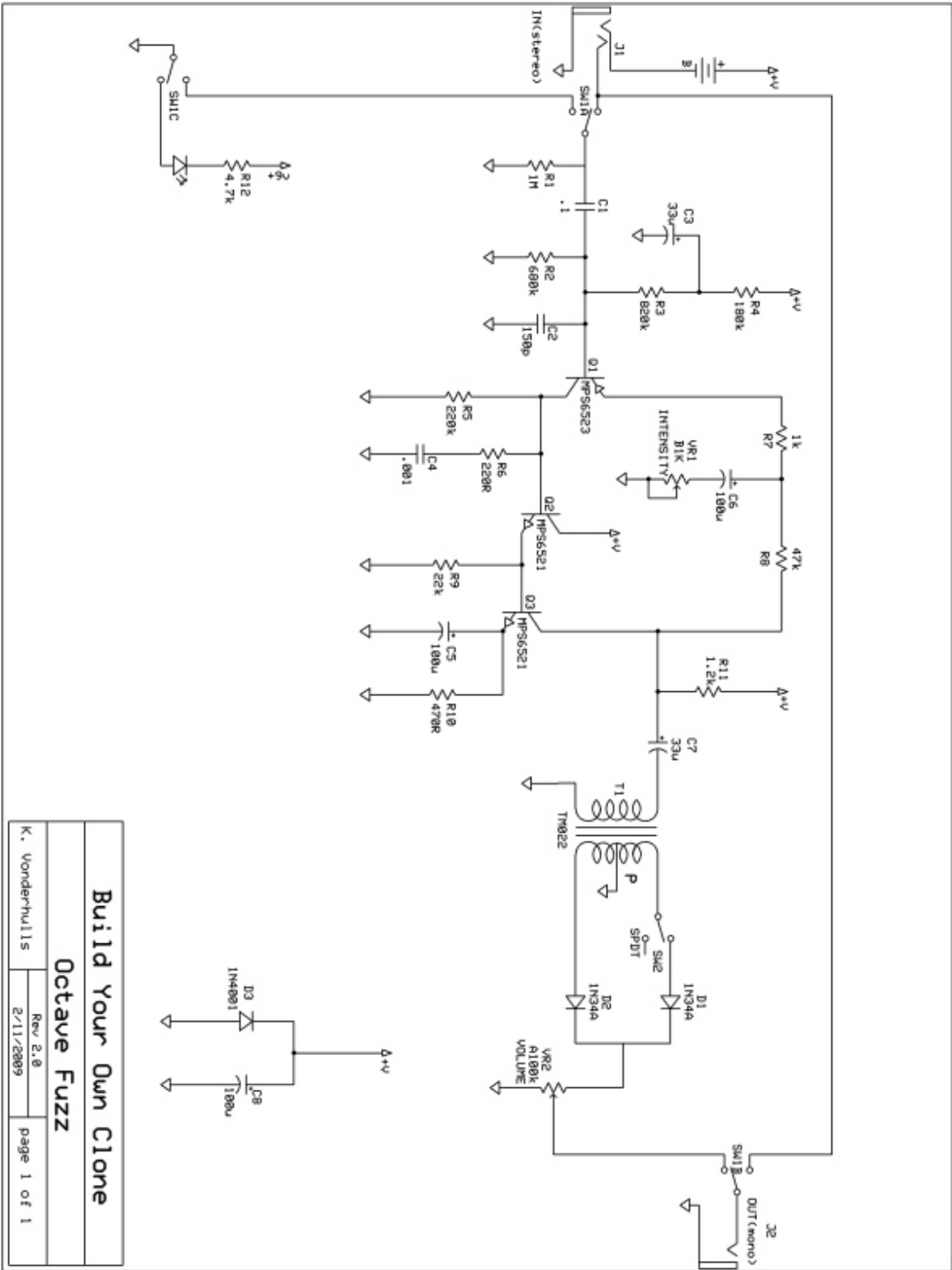

<b>Build Your Own Clone</b>	
<b>Octave Fuzz</b>	
K. Vonderhullis	Rev 2.0
2/11/2009	page 1 of 1

For high resolution image, visit: <http://byoceletronics.com/octavefuzzschematic.pdf>

**Please visit**  
<http://byoceletronics.com/board>  
**for any technical support**

**copyright 2018**  
**B.Y.O.C., LLC**