

Build Your Own Clone Optical Compressor Kit Instructions



Warranty:

BYOC, LLC guarantees that your kit will be complete and that all parts and components will arrive as described, functioning and free of defect. Soldering, clipping, cutting, stripping, or using any of the components in any way voids this guarantee. BYOC, LLC guarantees that the instructions for your kit will be free of any major errors that would cause you to permanently damage any components in your kit, but does not guarantee that the instructions will be free of typos or minor errors. BYOC, LLC does not warranty the completed pedal as a whole functioning unit nor do we warranty any of the individual parts once they have been used. If you have a component that is used, but feel it was defective prior to you using it, we reserve the right to determine whether or not the component was faulty upon arrival. Please direct all warranty issues to:

sales@buildyourownclone.com This would include any missing parts issues.

Return:

BYOC, LLC accepts returns and exchanges on all products for any reason, as long as they are unused. We do not accept partial kit returns. Returns and exchanges are for the full purchase price less the cost of shipping and/or any promotional pricing. Return shipping is the customer's responsibility. This responsibility not only includes the cost of shipping, but accountability of delivery as well. Please contact sales@buildyourownclone.com to receive a return authorization before mailing.

Tech Support:

BYOC, LLC makes no promises or guarantees that you will successfully complete your kit in a satisfactory manner. Nor does BYOC, LLC promise or guarantee that you will

receive any technical support. Purchasing a product from BYOC, LLC does not entitle you to any amount of technical support. BYOC, LLC does not promise or guarantee that any technical support you may receive will be able to resolve any or all issues you may be experiencing.

That being said, we will do our best to help you as much as we can. Our philosophy at BYOC is that we will help you only as much as you are willing to help yourself. We have a wonderful and friendly DIY discussion forum with an entire section devoted to the technical support and modifications of BYOC kits.

www.buildyourownclone.com/board

When posting a tech support thread on the BYOC forum, please post it in the correct lounge, and please title your thread appropriately. If everyone titles their threads "HELP!", then it makes it impossible for the people who are helping you to keep track of your progress. A very brief discription of your specific problem will do. It will also make it easier to see if someone else is having or has had the same problem as you. The question you are about to ask may already be answered. Here are a list of things that you should include in the body of your tech support thread:

1. A detailed explanation of what the problem is. (not just, "It doesn't work, help")
2. Pic of the top side of your PCB.
3. Pic of the underside of your PCB.
4. Pic that clearly shows your footswitch/jack wiring and the wires going to the PCB
5. A pic that clearly shows your wiring going from the PCB to the pots and any other switches(only if your kit has non-PC mounted pots and switches)
6. Is bypass working?
7. Does the LED come on?
8. If you answer yes to 6 and 7, what does the pedal do when it is "on"?
9. Battery or adapter.(if battery, is it good? If adapter, what type?)

Also, please only post pics that are in focus. You're only wasting both parties' time if you post out of focus, low res pics from your cell phone.

Revision Notes:

Rev 2.1(current) There are no known errors in this revision.

Go to: www.buildyourownclone.com/opticompV1.pdf to download instructions for the previous version of the optical compressor kit.

Copyrights:

All material in this document is copyrighted 2009 by BYOC, LLC

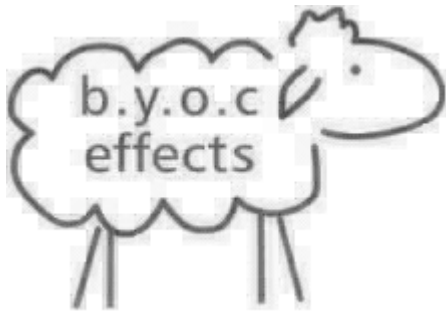

**OPTICAL COMPRESSOR KIT
OPTICAL COMPRESSOR KIT
INSTRUCTION INDEX**

Parts Checklist.....page 4 - 5

Populating the Circuit Board.....page 6 - 13

Assembly.....page 15 - 17

Wiring the Footswitch & Jacks.....page 18 - 20

Installing the IC.....page 21

Schematic.....page 22

Parts Checklist for BYOC Optical Compressor

Resistors:

- 2 - 4.7k (yellow/purple/black/brown/brown)
- 2 - 10k (brown/black/black/red/brown)
- 4 - 100k (brown/black/black/orange/brown)
- 2 - 220k (red/red/black/orange/brown)
- 1 - 470k (yellow/purple/black/orange/brown)
- 2 - 1M(brown/black/black/yellow/brown)

Capacitors:

- 1 - .01 μ f/1n film (10n)
- 4 - .047 μ f/47n film (47n)
- 3 - 0.1 μ f/100n film (100n) [use only for bass guitar]
- 2 - 33 μ f aluminum electrolytic
- 1 - 100 μ f aluminum electrolytic

Diodes:

- 1 - 1N4001

Transistors:

- 2 - 2N5088

IC's:

- 1 - 4558 or similar DIP-8 dual operational amplifier

Optocoupler:

- 1 - VTL5C4(single element with 4 leads) or VTL5C4/2(dual element with 5 leads)

Potentiometers: Be sure to snap off the small tab on the side of each panel mounted pot.

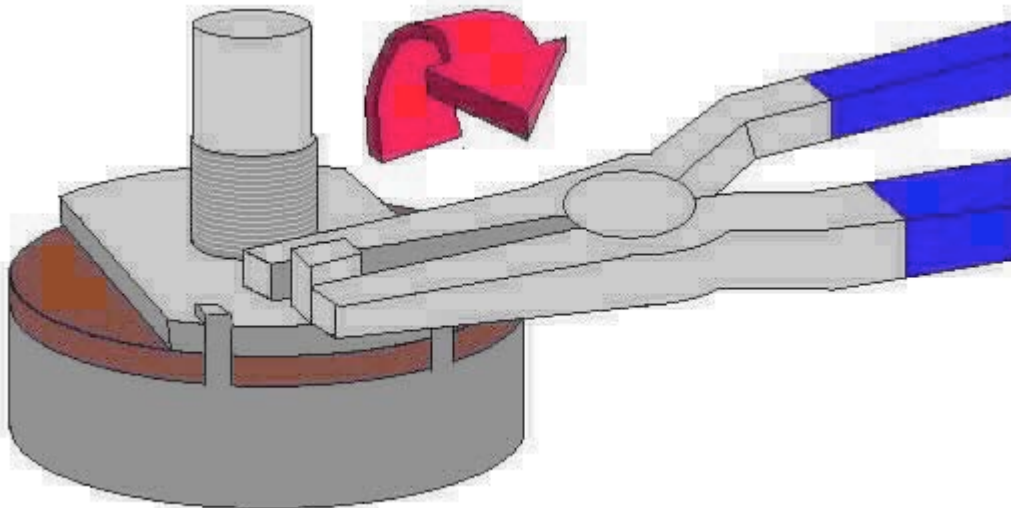

1 -

B500k linear (sustain knob)

1 - B500k linear (sustain knob)

1 - A100k audio(volume knob)

Hardware:

- 1 - drilled enclosure w/ 4 screws
- 1 - byoc Optical Compressor circuit board
- 1 - 3PDT footswitch
- 2 - knobs
- 1 - AC adaptor jack
- 1 - 1/4" mono jack
- 1 - 1/4" stereo jack
- 1 - red LED
- 1 - battery snap
- 4 - bumpers
- hook-up wire

Populating the Circuit Board

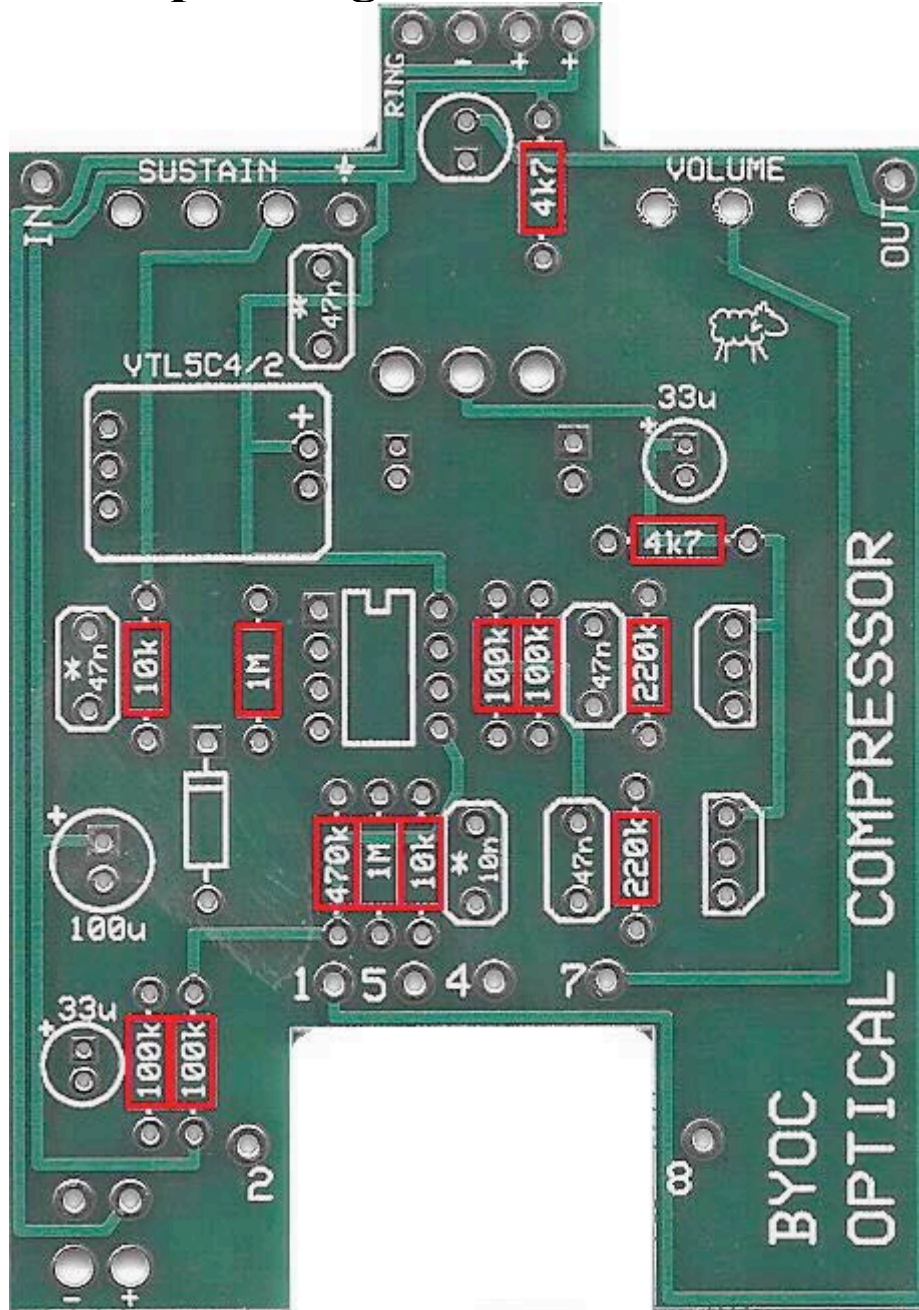

STEP 1: Add the resistors. Resistors are not polarized, so it does not matter which end goes in which solder pad.

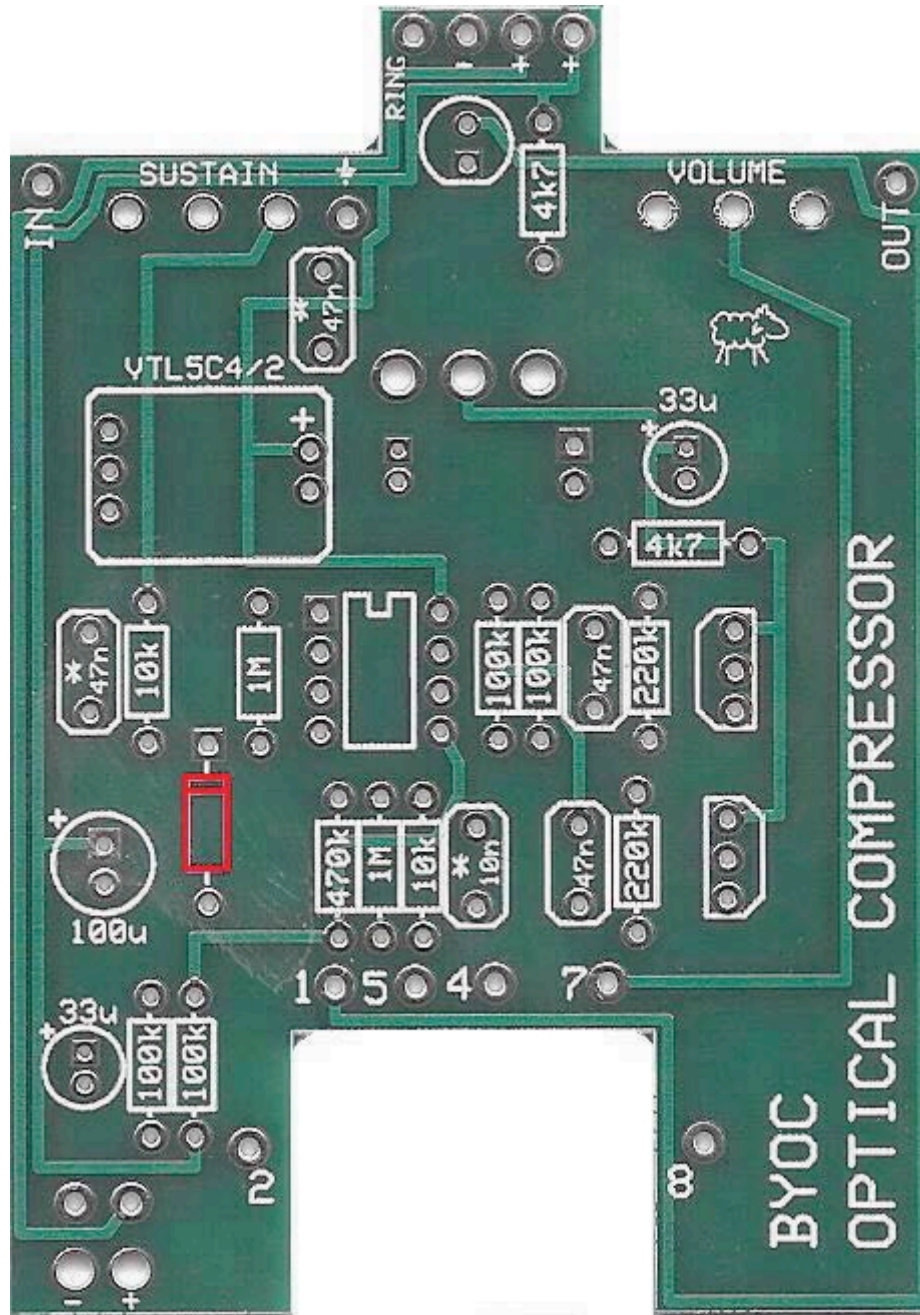

STEP 2: Add the diode. The 1N4001 will be black with a silver stripe. Be sure to matched the end of the diode with the stripe to the layout on the PCB. The stripped end should go in the square solder pad.

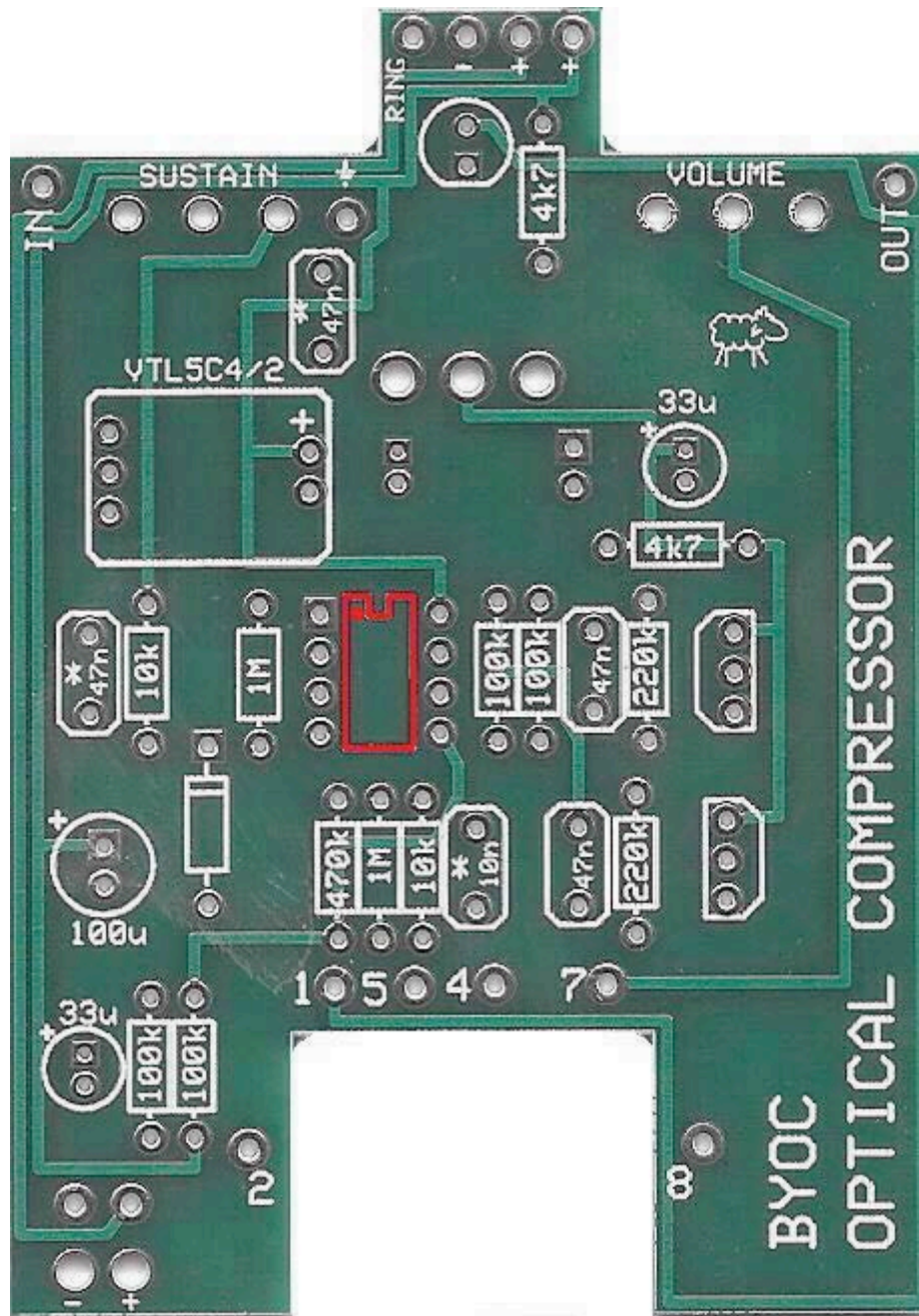

STEP 3: Add the IC socket. Line up the U shaped notch of the socket to the notch on the PCB layout. Solder only the IC socket to the PCB. Do not solder the actual IC. The IC inserts into the socket the same way you'd plug a vacuum tube into a socket. See page 21 for instructions on how to install the IC into the socket.

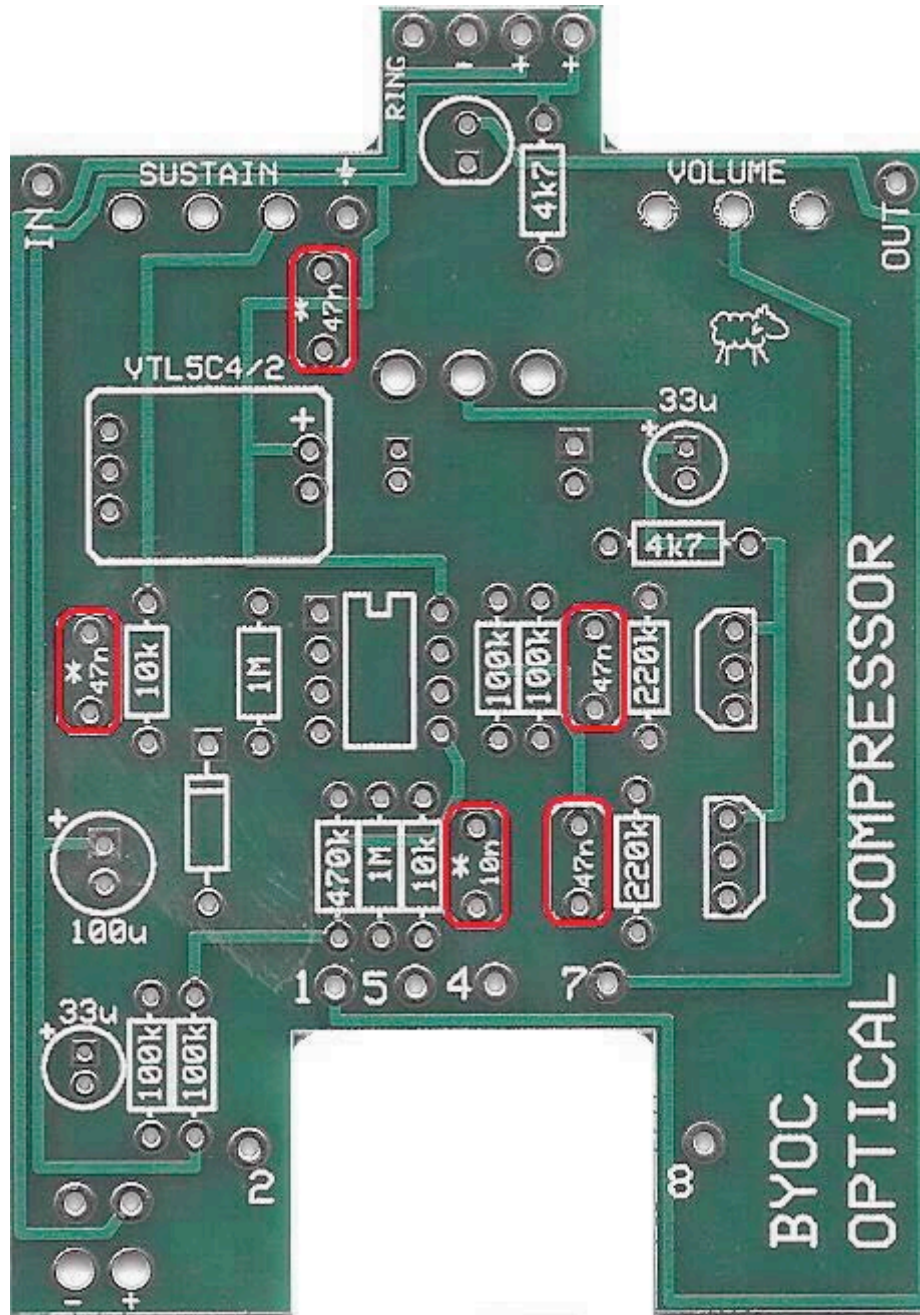

STEP 4: Add the film capacitors. These are not polarized so they can be inserted into the PCB in either direction. If you are building for use with bass guitar, you should use the .1uf(100n) capacitors in the places marked with an “*”.

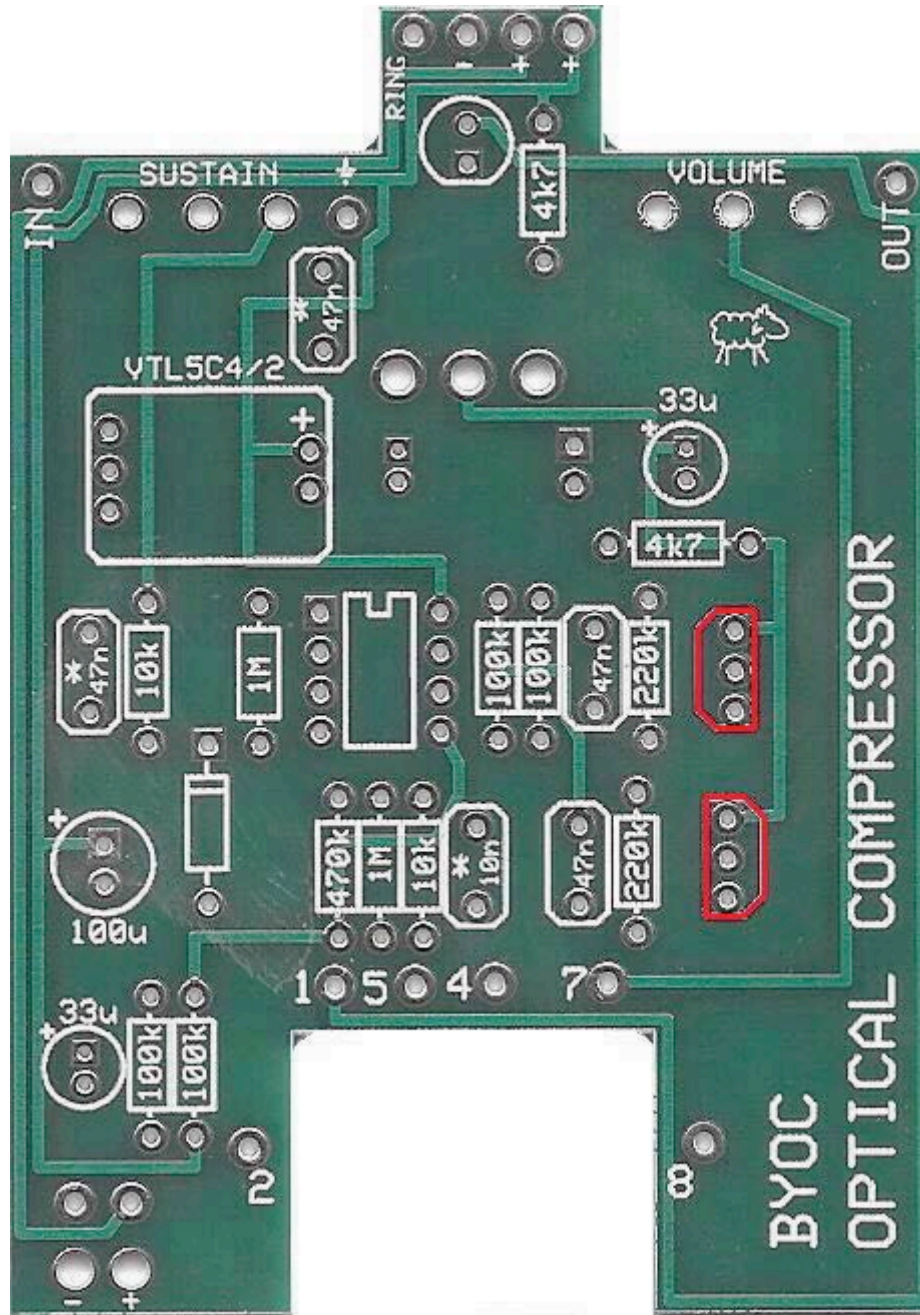

STEP 5: Add the transistors. Match the flat side of the transistor to the flat side of the layout on the PCB.

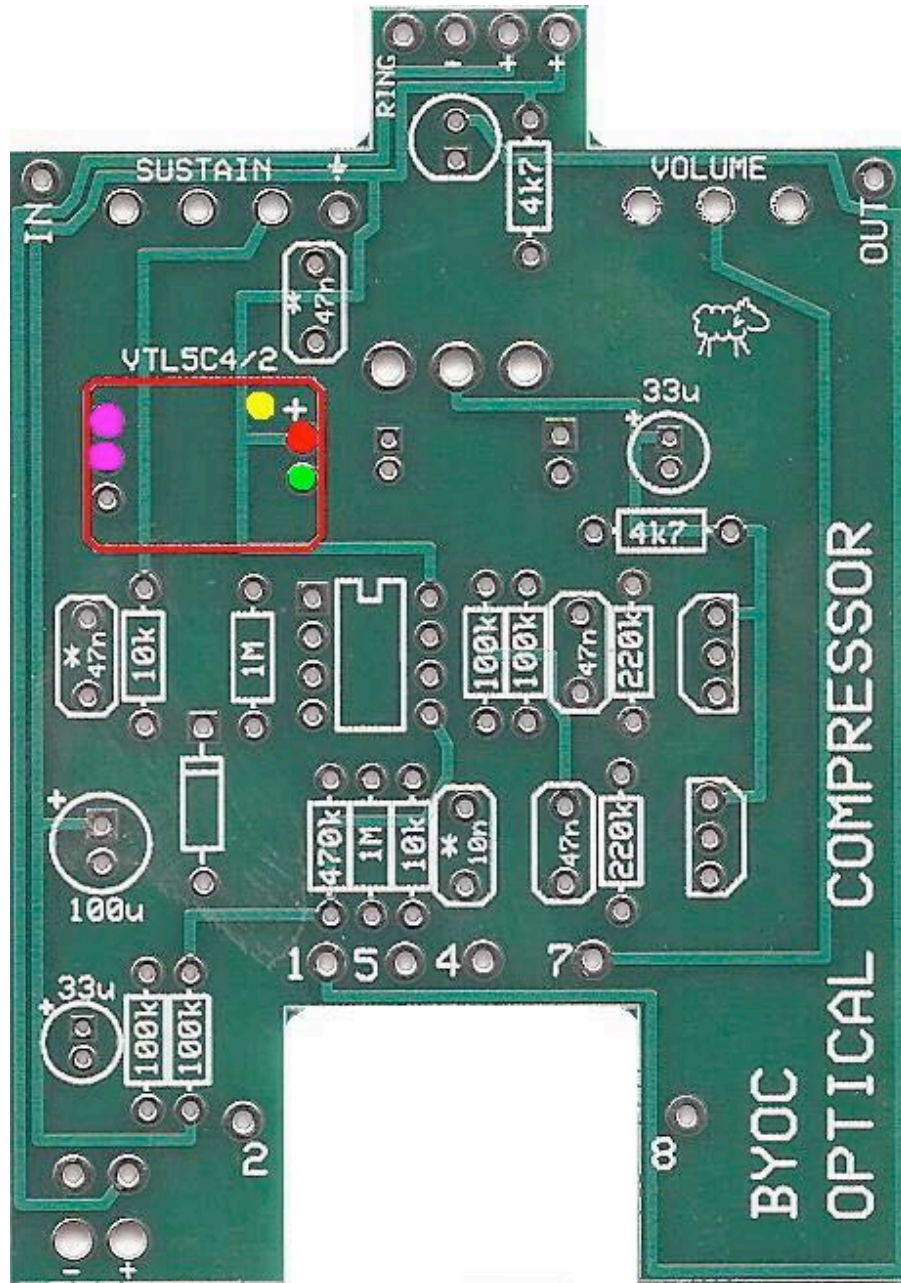

STEP 6: Add the optocoupler.

If your kit came with a VTL5C4(4 leads): Insert the optocoupler into the PCB so that the side with the yellow dot is facing up. Orient the optocoupler so that the yellow dot is pointing towards the positive (+) eyelet. The LED lead that goes in the positive (+) eyelet highlighted in red, should be slightly longer. The shorter LED lead goes in the eyelet highlighted in green. Insert one of the element leads into one of the element eyelets highlighted in purple. Insert the other element lead into the other element eyelet highlighted in purple. It doesn't matter which element lead goes in which element eyelet, but obviously you'd want to put them in the eyelets where they would naturally lay without crossing them or shorting them out against one another.

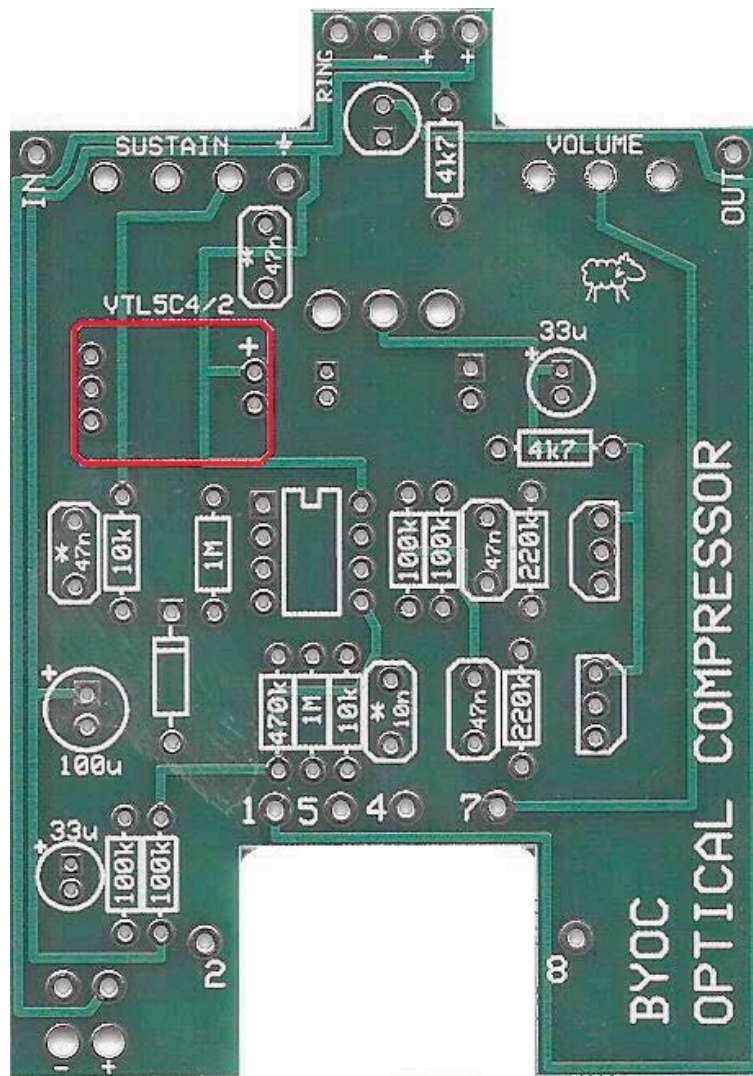

If your kit came with a VTL5C4/2(dual element with 5 leads): Orient the optocoupler so that the printed side is facing up and the “+” symbol on the optocoupler matches the “+” symbol on the PCB.

What's the difference between the VTL5C4/2 and the VTL5C4? Nothing as far as this pedal is concerned. They have the same specs, but the VTL5C4/2 has dual elements. We only need one of the elements for this compressor.

Why bother using the VTL5C4/2 if you only need one of the elements? Economy of scale. We already had a kit (DOD440 clone) that needed the dual element VTL5C4/2. Even though the dual element version is more expensive than the single element version, it was still more cost effective for us to purchase twice as many VTL5C4/2 for both this kit and the 440 clone kit, rather than half as many of each. We no longer make the 440 clone kit, so now we're using the single element version.

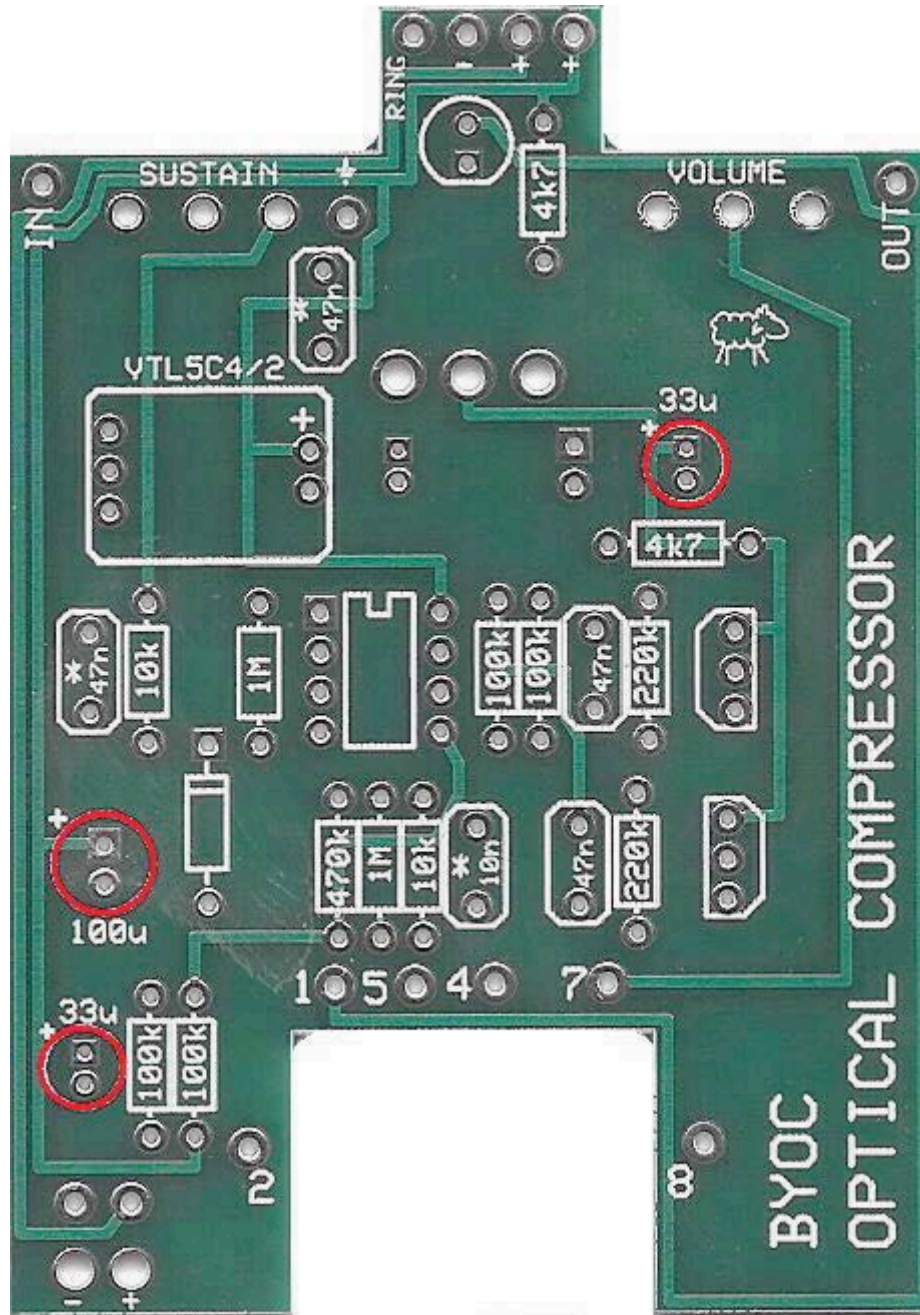

STEP 7: Add the aluminum electrolytic capacitors. These are polarized. The positive end will have a longer lead and should go in the square solder pad. The negative end will have a shorter lead with a black strip running down the body of the capacitor.

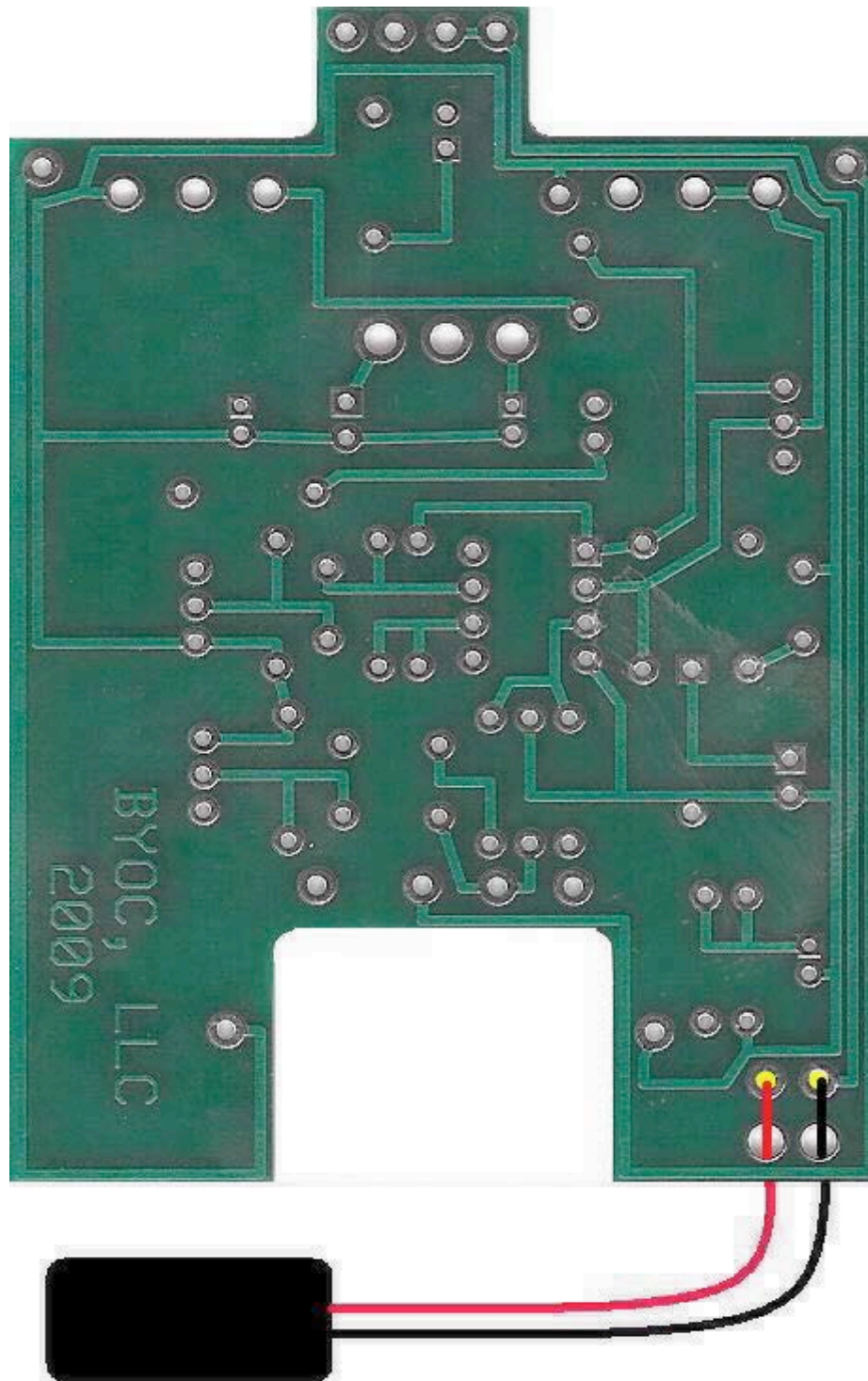

Step 8: Add the battery snap. Thread the solder ends of the snap through the under side of the strain relief holes. Insert the stripped ends of the battery snap wires into the topside of their respective solder pads. Solder on the bottom side where highlighted in yellow. Remember the red wire goes in the “+” hole and the black wire goes in the “-” hole.

Step 3: Flip the PCB over so that the bottom or solder side is up. Insert the two potentiometers and the LED into the bottom side of the PCB. DO NOT SOLDER!!!

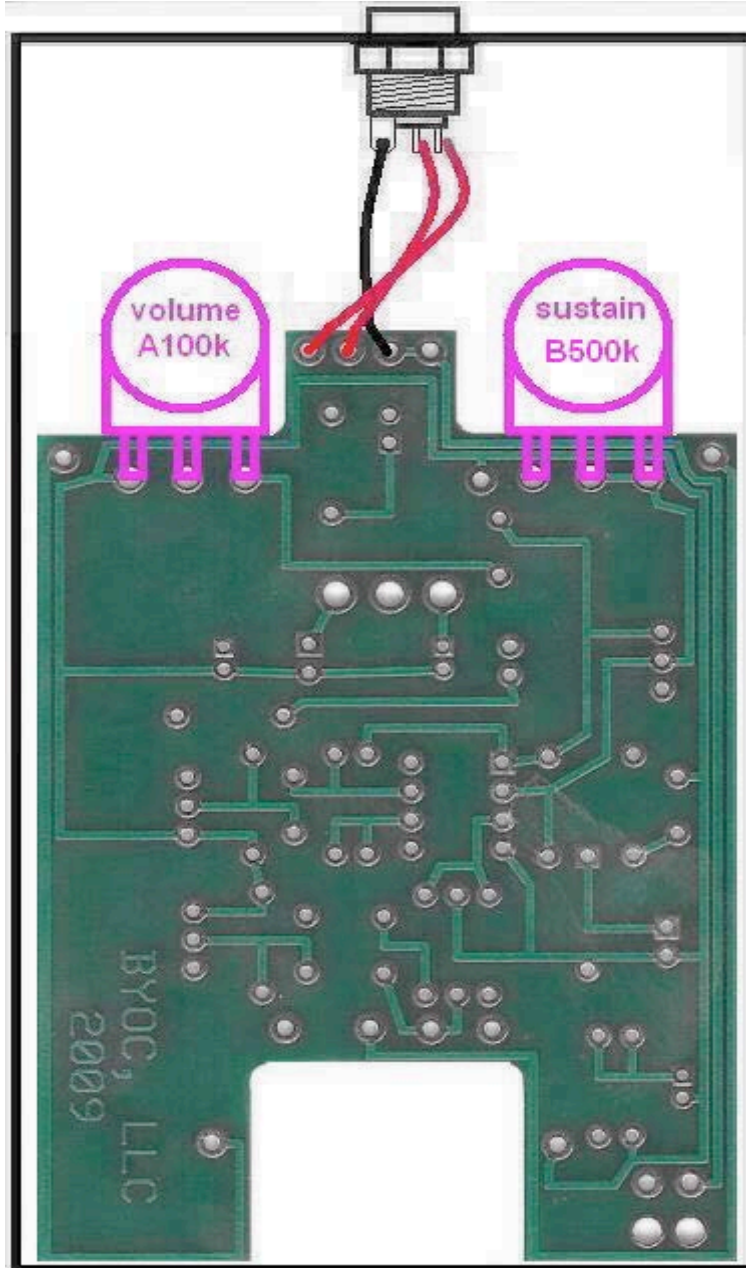

Step 4: Hold the PCB in one hand so that the component side of the PCB is in the palm of your hand and the bottom side with the pots and LED is facing up. Now use your other hand to guide the predrilled enclosure onto the PCB assembly so that the pots and LED all go into their respective holes. **Place the long lead of the LED into the square hole.** Once the PCB assembly is in place, secure it by screwing on the washers and nuts for the pots and toggle switch. Only tighten them with your fingers. You do not want them very tight yet. Be sure to keep your hand on the PCB so that it does not fall off the PC mounting posts of the pots and toggle switch.

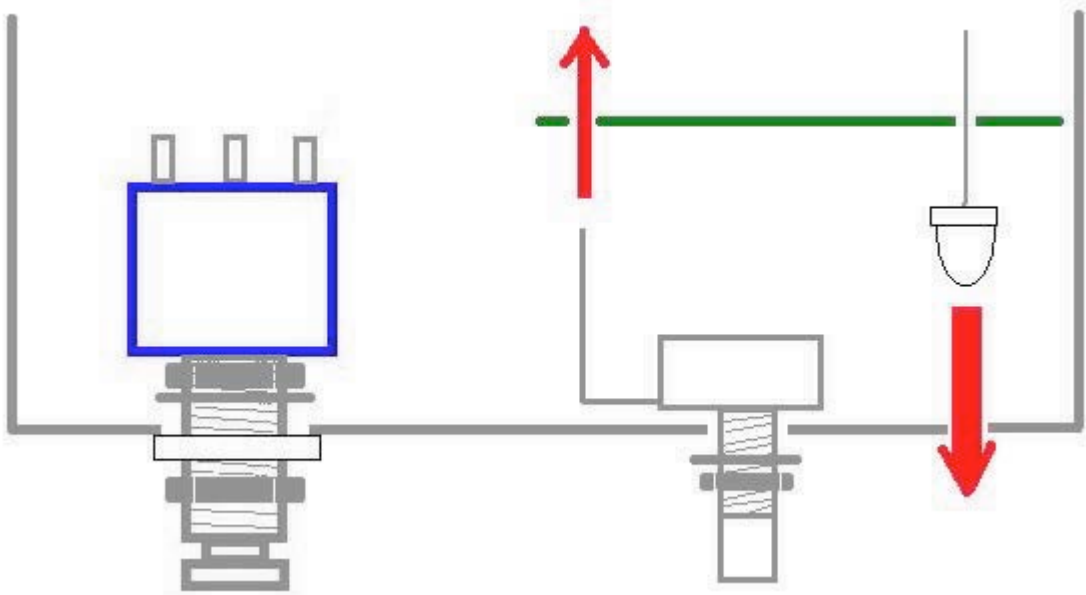

Step 5: Turn the entire pedal over so that the component side of the PCB is facing up. Lift the PCB up off the pots about 2mm just to make sure that the back of the PCB does not short out against the pots. Make sure the PCB is level and symmetrically seated inside the enclosure.

Step 6: Snug the nuts of the pots tight with your fingers and solder the pots and LED. You will solder these parts on the top component side of the PCB.

Wiring the footswitch, and jacks

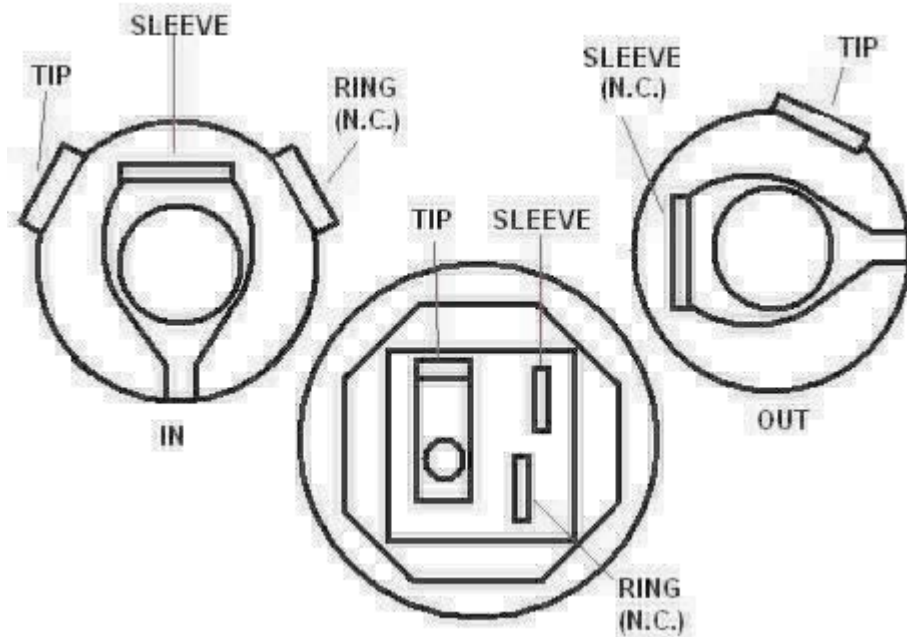

Step 1: Install the 1/4" jacks on the enclosure. Be sure to turn the OUT jack a 1/4 turn counter clockwise so that solder terminal for the tip does not short out against the enclosure.

Step 1: Install the 1/4" jacks on the enclosure. Be sure to turn the OUT jack a 1/4 turn counter clockwise so that solder terminal for the tip does not short out against the enclosure.

Step 2: Install the footswitch on the enclosure. Orient the footswitch so that the flat sides of the solder lugs are horizontal. You can turn it 180 degrees. Either way is fine, just don't orient the foot switch so that the flat sides of the solder lugs are vertical.

Footswitch Solder Lug Designations

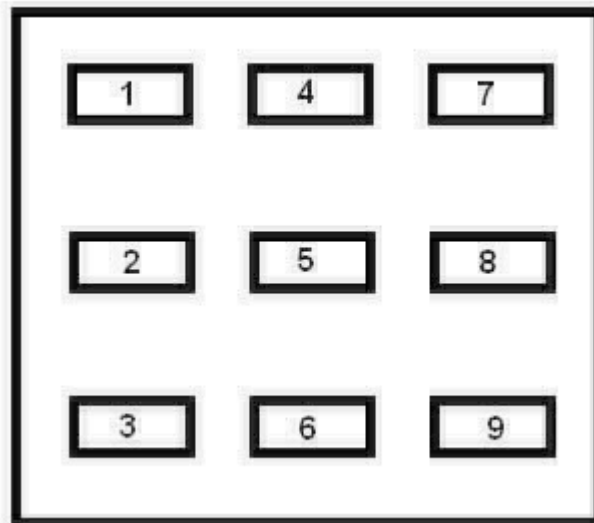

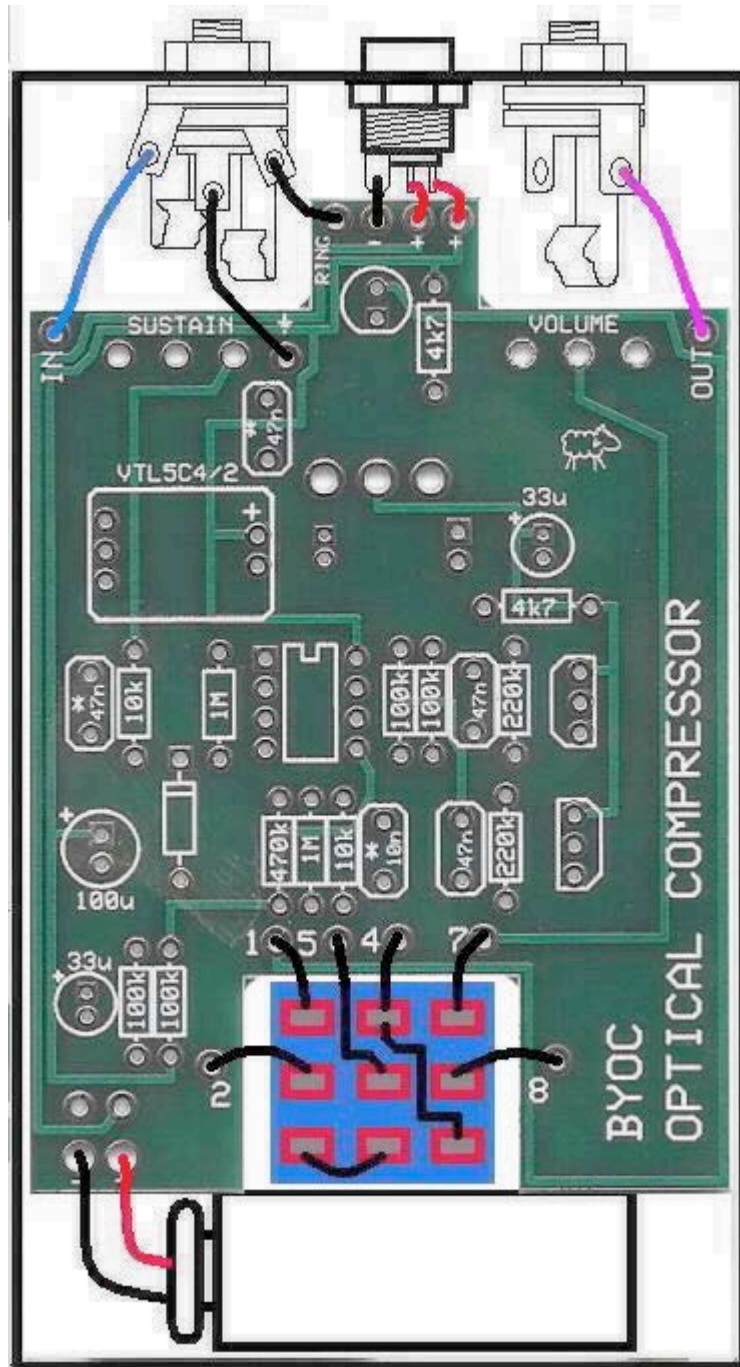

Step 2:

- Cut 4 x 3/4" pieces of wire. Strip 1/8" off each end. These will be used to connect lugs/eyelets 1, 2, 7, & 8
- Cut 1 x 1" piece of wire. Strip 1/8" off each end. This will be used to connect lug/eyelet 5
- Cut 1 x 1.5" peice of wire. Strip 1/8" of one end. Strip 1/2" off the other end. This will be used to connect lug/eyelet 4. The longer stripped end will be used to jumper lug 4 to 9.

- Cut 3 x 2" pieces of wire. Strip 1/4" off each end. These will be used to connect the tip and sleeve of the IN jack and the tip of the OUT jack to the PCB.
- Cut 1 x 1.5" peice of wire. Strip 1/4" off each end. This will be used to connect the ring of the IN jack to the ring eyelet on the PCB

Step 3: Remove the PCB assembly from the enclosure.

Step 4: Solder all the wires to their respective places on the PCB but to not solder to the jacks or footswitch yet. Load the wires in from the top of the PCB and solder on the bottom side.

Step 5: Reinstall the PCB assembly to the enclosure.

Step 6: Solder the open ends of the wires that you just soldered to the PCB to their respective solder lugs on the footswitch and jacks.

Installing the IC

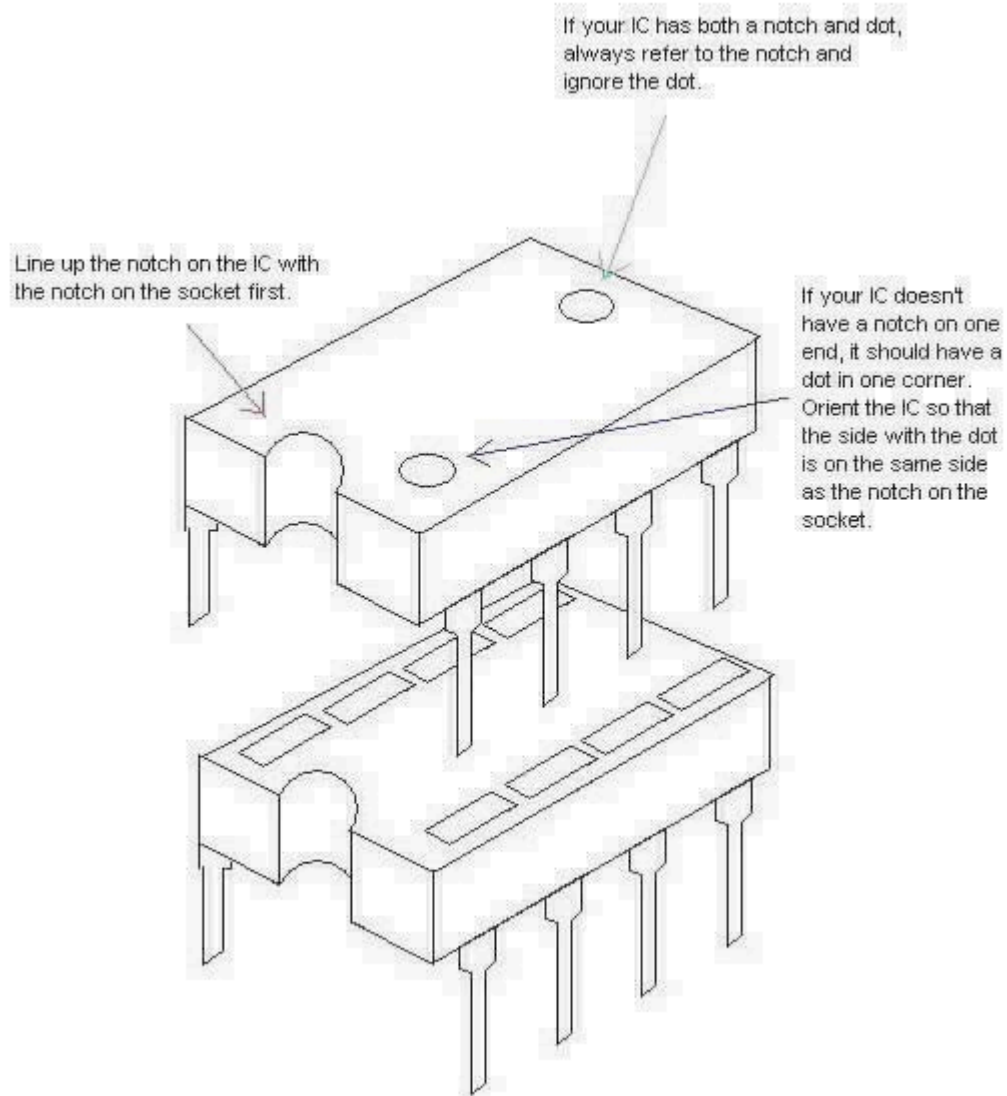

Please visit
<http://byoceletronics.com/board>
for any technical support

copyright 2009
B.Y.O.C., LLC